

WHEELCHAIR TENNIS INSTRUCTORS MANUAL



First Wheelchair Instructor Course in Canada: North Vancouver Tennis Centre – May 2003



Version 4.8 April 2015

Programme
national de
certification des
entraîneurs



National
Coaching
Certification
Program



TABLE OF CONTENTS

INTRODUCTION	IV
WHEELCHAIR TENNIS INSTRUCTOR MANUAL 'MIND MAP'	V
WHEELCHAIR TENNIS	1
1. THE WHEELCHAIR GAME	1
A) HISTORY OF WHEELCHAIR TENNIS.	1
B) WHEELCHAIR TENNIS IN CANADA.	2
2. THE PLAYER	3
A) INJURY LEVELS.	3
B) DIVISIONS.	4
C) INTEGRATION PHILOSOPHY.	4
D) COMMUNICATION PHILOSOPHY.	4
E) PLAYING LEVELS.	5
3. EQUIPMENT	6
A) FACILITY REQUIREMENTS.	6
B) ADDITIONAL EQUIPMENT	6
C) THE CHAIR	8
4. RULES	9
A) THE TWO BOUNCE RULE	9
B) THE WHEELCHAIR	9
C) THE SERVICE	9
D) PLAYER LOSES POINT	9
E) PROPELLING THE CHAIR FOOT	10
F) WHEELCHAIR/ABLE-BODIED TENNIS.	10
G) POWER WHEELCHAIRS	10
CHECK YOUR UNDERSTANDING	11
HELPING PLAYERS TO LEARN TENNIS	12
1. APPROACHES TO LEARNING THE GAME	13
A) COACHING EVOLUTION	13
2. DEVELOPMENT PATH	15
A) DEVELOPMENT PROGRAMS	15
B) RED.ORANGE, GREEN TENNIS.	17
3. BASIC TACTICAL SITUATIONS	21
A) SINGLES	21
B) DOUBLES.	22
CHECK YOUR UNDERSTANDING	24

Table of contents ... continued

TECHNICAL DEVELOPMENT 25

1. DEVELOPING TECHNIQUE 25

 A) PRINCIPLE BASED TECHNIQUE. 25

 B) DEFINITION OF TECHNIQUE 25

2. TECHNICAL CONSIDERATIONS 27

 A) BALANCE 27

 B) GROUNDSTROKES 28

 C) SERVE & OVERHEAD 28

 D) VOLLEYS 28

3. BALL FEEDING 23

 A) DEAD BALL VS LIVE BALL FEEDING. 23

 B) FEEDING RECOMMENDATIONS. 23

 C) DEVELOPING SELF-SUFFICIENCY. 23

CHECK YOUR UNDERSTANDING 29

MOBILITY 30

1. NEUTRAL POSITION 31

 A) CONTACT POINTS. 31

 B) READY POSITION/BALANCING THE PUSH 31

2. MANEUVERING. 31

 A) PUSHING 31

 B) BRAKING 32

 B) TURNING 32

3. PREPARATION 33

4. RECOVERY 33

 A) CIRCULAR MOBILITY. 33

 B) RECOVERY TRIANGLE 34

 C) RECOVERY TIMING 35

 D) MOBILITY CYCLE EXAMPLE 35

5. MOBILITY DRILLS. 36

 A) GENERAL MOBILITY DRILLS. 36

 B) SITUATIONAL MOBILITY DRILLS 37

CHECK YOUR UNDERSTANDING 39

RESOURCES/ACKNOWLEDGEMENTS 40

TABLE OF FIGURES

1) SPINAL CORD INJURIES. 3	14) MOBILITY CYCLE. 29
2) PLAYING LEVELS. 5	15) CONTACT POINTS 30
3) ADDITIONAL EQUIPMENT 6	16) READY POSITION/BALANCED PUSH. 30
4) ANATOMY OF A CHAIR 8	17) TURNS 31
5) MODEL VS GAME-BASED APPROACH. 13	18) CROSS HAND TURN. 31
6) RED COURT SET-UP. 16	19) PREPARATION 32
7) ALTERNATIVE RED COURT SET-UP 17	20) REVERSE MOBILITY. 33
8) ORANGE COURT SET-UP 17	21) "INTERSECT VS 'BISECT' 33
9) ORANGE COURT COMPETITION SET-UP. . . 18	22) RECOVERY LOCATIONS' 34
10) PROGRAMS & STAGES. 19	23) MOBILITY CYCLE EXAMPLE 35
11) DOUBLES – TWO BACK. 21	24) GENERAL MOBILITY DRILLS. 36
12) DOUBLES-ONE UP/ONE BACK. 21	25) SITUATIONAL MOBILITY DRILLS. 37
13) TECHNICAL DEVELOPMENT CHART. 24	

INTRODUCTION

Instructing wheelchair tennis is both challenging and rewarding. Wheelchair tennis is one of the fastest growing and most exciting sports for people with a disability. It is played by people of all ages and abilities, and is one of the few sports where people with and without disabilities can enjoy the sport together.

As wheelchair tennis grows around the world and in Canada, the demand and need for trained coaches will increase. The manual is targeted for the introductory levels of play and is designed to equip instructors with all the necessary tools to take wheelchair players from the beginner to intermediate levels of play.

Most of the tennis principles that apply to the able-bodied game apply to wheelchair tennis, especially in areas such as strokes, grips, tactics, corrective techniques, teaching methodologies, progressions, mental training, and match preparation. **Remember, wheelchair tennis is tennis (only played from a seated position).** The similarities between wheelchair tennis and tennis go way beyond the rules, making it very easy for tennis coaches to understand. The major differences lie in the mobility areas.

This manual focuses on the areas of difference and coaching information that must be adapted when instructing wheelchair tennis. The key competencies covered in the wheelchair course include:

1. **Coaching Communication:**
 - Be able to use a cooperative coaching communication style to build rapport with students
 - Be able to communicate in an enthusiastic, professional and caring manner.
2. **Tactical/Technical knowledge:**
 - Understand wheelchair tennis equipment (chair, strapping, racquet, quad taping)
 - Understand a “Game-based” development path for introductory players
 - Understand basic tactics for singles & doubles
 - Understand the Mobility Cycle
 - Understand how to evaluate and correct effectiveness using the 5 Ball Controls
 - Understand basic technical fundamentals as applied to wheelchair tennis
3. **Implementation:**
 - Be able to introduce, set-up and run mobility drills
 - Be able to evaluate, train, and progress basic technical fundamentals
 - Be able to take introductory players through a basic development path

These competencies will help you feel more professional and ready to instruct wheelchair players.

Wayne Elderton

Consultant, National Wheelchair Program. Tennis Canada Head of Coaching Development & Certification in BC.

Please note that this manual has been designed as a supplement to the Tennis Canada Instructor course materials. All the material for general instruction is covered in the Instructor materials with specific wheelchair application outlined in this manual.

WHEELCHAIR TENNIS INSTRUCTOR MANUAL “MIND MAP” SUMMARY CHART



HELPING PLAYERS LEARN TENNIS

- APPROACHES TO LEARNING THE GAME
- DEVELOPMENT PATH
- BASIC TACTICAL SITUATIONS
(SINGLES/DOUBLES)

TECHNICAL DEVELOPMENT

- DEVELOPING TECHNIQUE
 - Principle based technique
 - Definition of technique
- TECHNICAL CONSIDERATIONS
 - Balance
 - Groundstrokes
 - Serve/Overhead
 - Volleys
- BALL FEEDING
 - ‘Dead’ vs ‘Live’ ball feeding
 - Feeding recommendations
 - Developing self-sufficiency

MOBILITY

- MOBILITY CYCLE
 - Neutral position
 - Maneuvering
 - Preparation
 - Recovery
- MOBILITY EXAMPLE
- MOBILITY DRILLS



WHEELCHAIR TENNIS

1. THE WHEELCHAIR GAME

A) HISTORY OF WHEELCHAIR TENNIS

Wheelchair tennis is the most popular and fastest growing sport for people with physical disabilities. One of the top-four Paralympic sports, wheelchair tennis boasts a full international circuit of tournaments worldwide. There are international rankings in the men's, women's and quad divisions. Teams from various countries compete annually in the World Team Cup. The sport is professionally managed by the International Tennis Federation, which strives to provide opportunities for the top players in the world as well as those who have just started to play.

It all began in 1976 when, in his third year of competitive acrobatic skiing, 18 year-old Brad Parks was injured while taking his first warm-up jump in a local free-style competition. Five months later, Brad tried hitting tennis balls from his wheelchair using two bounces. He then met Jeff Minnenbraker, a rehab therapist, who had also been experimenting with tennis.

Over the next few years Brad and Jeff played extensively, developed tennis chairs and offered camps and exhibitions to promote the sport throughout California. The first tournament took place in 1977 and by 1980 the National Foundation of Wheelchair Tennis was formed.

In 1982, France became the first country in Europe to put a wheelchair tennis program in place. By 1985, over 1,500 players took part in 40 sanctioned tournaments in the U.S alone. An international team competition, the World Team Cup, was also established with six men's teams.

In 1988, the International Wheelchair Tennis Federation was founded at a meeting during the U.S Open in Irvine, California. Membership was accorded to eight countries including Canada. In 1992, Tennis Australia was the first National Governing Body to employ a full-time coordinator for tennis for people with disabilities. In 1997, history was made at the ITF's AGM in Cairo, when their members voted that wheelchair tennis should become a fully integrated part of the ITF, in the same manner as other sectors of the game, such as Juniors and Seniors.

The USTA and Tennis Canada have followed suit and are now the official governing bodies for wheelchair tennis in their respective countries. The sport continues to grow and the World Team Cup now boasts players in the men's, women's, quad and junior divisions from many countries.

B) WHEELCHAIR TENNIS IN CANADA

Wheelchair tennis was played in Canada in the 70's and 80's and managed by the Canadian Wheelchair Sports Association. In 1998, the sport followed international trends and Tennis Canada became the official governing body. A part-time Wheelchair Tennis Manager was hired to oversee the development of the sport.

Wheelchair tennis is well organized with programs and activities at the national, provincial and community levels. Tennis Canada has developed a solid National Team Program for Canada's top ranked players that includes competing in the World Team Cup, international competitions, training camps, Sport Canada carding, and the opportunity to work directly with Tennis Canada Touring Coaches.

The Canadian Wheelchair Tennis Circuit consists of national, provincial and local tournaments including ITF sanctioned events and the National Championships. Canadian rankings are compiled in several divisions and Canada boasts some of the world's top players. Tennis Canada offers a Wheelchair Tennis Instructor Certificate Program to upgrade and solidify the skills of coaches working with wheelchair players. Tennis Canada also liaises with the Provincial Associations in the development of new players.

Provincial Wheelchair Sport Associations collaborate with Provincial Tennis Associations in the delivery of development programs across each province. Introductory clinics, developmental programs for new players, tournaments and special events are organized in many provinces.

Wheelchair tennis is gaining exposure at the community level and many clubs are becoming wheelchair accessible and offering programs for players. More and more coaches, volunteers, media, and sponsors are becoming aware of the sport and its benefits to people of all ages with physical disabilities.

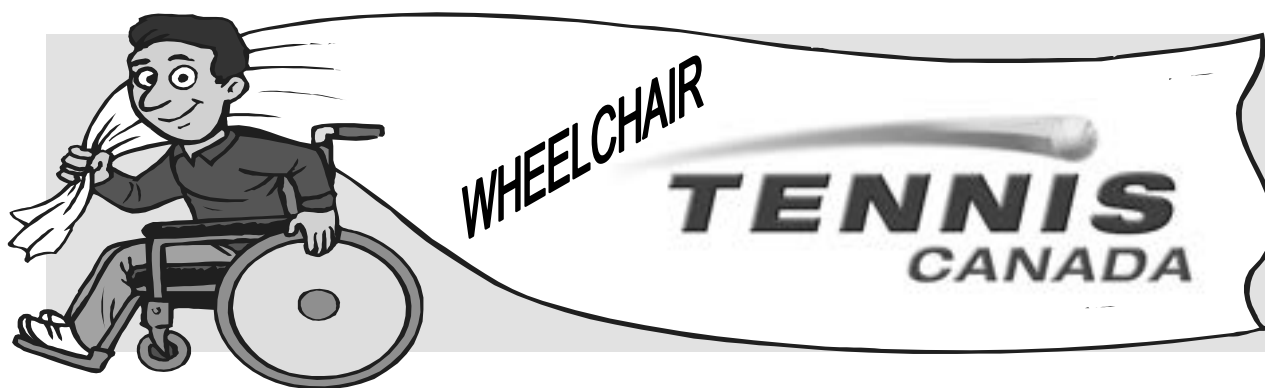

2. THE PLAYER

A) INJURY LEVELS

The level and degree of Spinal Cord Injury (SCI) will affect the player's balance, available range of motion, and mobility. Knowing about the student's injury level helps in adapting techniques and drills to the individual student's capabilities. The following SCI classification can help an instructor determine the students' capabilities.

The lowest level on the spinal cord that exhibits intact motor and sensory function classifies spinal cord injuries. For example, a player classified "T3" was injured at that vertebrae.

It is also important to note that a player's injury can be *complete* or *incomplete*. The later will allow some function below the level of injury. The diagram shows the level of injury and what muscles might be affected.

FIGURE 1:
The Spine

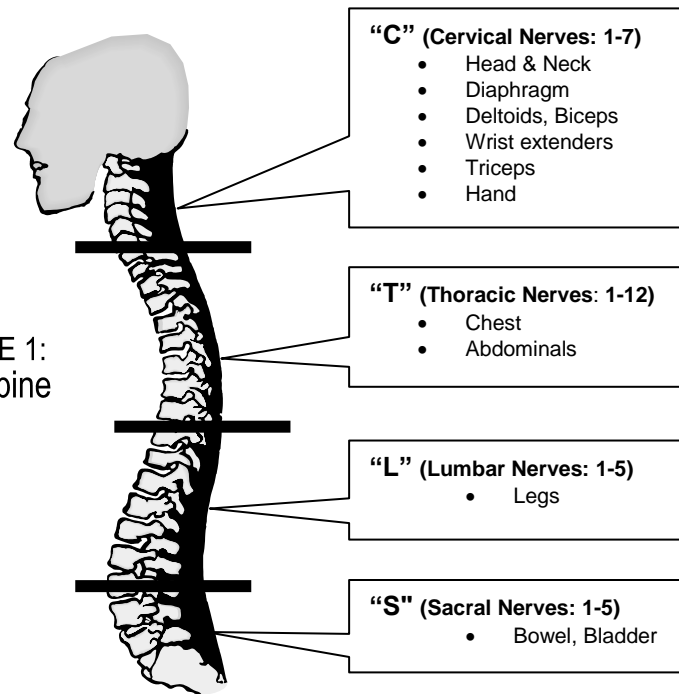

COACHING NOTE: *It is not a requirement of wheelchair instruction to be an 'expert' in all the possible injuries and limitations they produce. It is always best to ask the player to show you their specific movement capabilities related to the requirements of wheelchair tennis. With a few questions, you can ask (and see) what your student is capable of.*

In order to be eligible to compete in ITF sanctioned wheelchair tennis tournaments, players must have a medically diagnosed permanent mobility related physical disability. There are two playing divisions in wheelchair tennis and players qualify as follows:

- **Open:** A variety of disabilities including a 'Paraplegic' (defined as a person with permanent loss of function in one or both lower extremities). This includes amputees ("Amps")
- **Quad:** A 'Quadriplegic' is a player with a disability as defined above with the addition of permanent loss of function in one or both upper extremities. They must have a minimum of 3 limbs affected.

For more details regarding eligibility requirements, refer to the ITF website (www.ifttennis.com).

B) DIVISIONS

For tennis, there are a number of competitive divisions to group players in similar levels of challenge. Players can “play-up” in any division (they may have to qualify depending on the competition) but are not allowed to compete in divisions they are not classified for (e.g. someone who is not classified as a Quad may not play in the Quad division).

Typical divisions are:

- **Mens**
- **Womens**
- **Quad**
- **Junior** (under 18)

Some events may have lower skill level divisions for newer players. For eligibility requirements, please see the rules section.

C) INTEGRATION PHILOSOPHY

It is highly recommended that you attempt to integrate wheelchair players into your existing stand-up tennis programs. Wheelchair tennis has enough similarities to mix stand-up and wheelchair players as long as they are at compatible levels (see levels chart). Only the introductory levels of wheelchair instruction require specialty ‘wheelchair only’ programs. It is often difficult to find enough wheelchair players at each level to make wheelchair only groups. The result is an inconsistent development path. Integration takes courage and education on the part of the coach, wheelchair player, and stand-up participants, but is well worth it.



The rules of wheelchair tennis are designed so stand-up players can compete with wheelchair players (except that wheelchair players get 2 bounces). Doubles events where a stand-up player is paired with a wheelchair player (called an “Up and Down” event) are a popular way to integrate players.

D) COMMUNICATION PHILOSOPHY

Dealing with wheelchair players may be intimidating and unfamiliar for some Instructors at first. It can also be intimidating for the wheelchair player as playing a sport can emphasize their challenges. It may also be embarrassing being grouped with other students who may be more skilled (wheelchair or stand-up). Here are a few recommendations:

- Treat wheelchair players as tennis players (rather than ‘special needs’ people)
- When working with persons with disabilities, building self-esteem is an important factor. Positive reinforcement is especially important.
- Tennis is a technically difficult game requiring strength, dexterity, hand-eye coordination, and other elements that persons with spinal cord injuries may be limited by. Thus, patience and flexibility are important traits for the instructor.

E) PLAYING LEVELS

These rating guidelines are an excellent tool to identify and describe different levels of tennis ability. It allows a player or coach to group players into appropriate training or competition levels as well as see progress.

The guidelines use the Tennis Canada Play Tennis Self rating system so wheelchair players can be compared to stand-up players for integrated instruction and play. Also included is the International Tennis Federation's ITN (International Tennis Number) rating system equivalent. Please note that for comparison, Top International Open Wheelchair players can typically compete with 4.0 or 4.5 stand-up players. Top Quad players can typically compete with 3.0-3.5 level stand-up players.

FIGURE 2: Playing Levels

Play Tennis Level	ITF ITN #	Groundstrokes	Serve	Return	Net Play
.1	10.3	This is a category for wheelchair players only. This player has a debilitating or degenerative disease that severely inhibits motor function			
.5	10.2	This category is for wheelchair players only. This player is a 'typical' wheelchair player who has very little or no previous tennis experience.			
1.0	10.1	A beginning wheelchair player with good athletic ability, with a high injury can start at the same level as a beginner stand-up player.			
1.5	10	This player has been introduced to the game but has difficulty playing due to lack of consistency in rallying and serving			
2.0	9	Can get to the ball but lacks control, resulting in inconsistent rallies. Often chooses to hit forehands instead of backhands.	Incomplete service motion. Toss is inconsistent. Double faults are common.	Tends to position to protect weakness. Inconsistent returns.	In singles, reluctant to come to net. In doubles, understands basic positioning; comfortable only with the forehand volley; avoids backhand volley & overhead.
2.5	8	Can rally consistently 10 balls in a row, over the net at moderate speed, with an arced trajectory, especially on the forehand.	Attempting a full service motion on 1 st serve. Still inconsistent (less than 50%). Uses incomplete motion to ensure consistent 2 nd serve.	In singles, consistent when returning to the middle of the court. In doubles, difficulty starting the point with a crosscourt return.	Becoming at ease at net in practice but uncomfortable in a game situation.
3.0	7	Can rally 10 balls in a row consistently using forehands & backhands. Able to maintain a moderate paced rally when receiving high, short, or wide balls.	Full motion on both serves. Able to achieve more than 50% success on 1 st serve. 2 nd serve much slower than 1 st .	Can control the direction of the ball when receiving moderate paced serves.	Very consistent on moderate paced balls to forehand volley. Inconsistent on backhand. Overall difficulty with low and wide balls. Can smash easy lobs.
3.5	6	Able to move the opponent around the court or hit harder when receiving easier balls. Can perform approach shots with over 50% consistency.	Can vary speed or direction of 1 st serve. Can direct 2 nd serve to opponent's weakness without double-faulting regularly.	Can return fast or well placed serves defensively. Can return an easier serve with pace or placement. Can approach the net in doubles.	Becoming consistent on volleys and overheads requiring moderate movement. Can direct FH volley. General difficulty putting volleys away.
4.0	5	Able to develop points consistently by using a combination of shots. Erratic when attempting a quality shot from a fast or well placed ball or when attempting a passing shot.	Can vary the speed and direction of the 1 st serve. Can use spin.	Has difficulty returning very fast or spin serves. Can hit a good shot or exploit an opponent's weakness on moderate paced serves	Can follow an approach shot to net. In doubles can receive a variety of balls and volley offensively. Can poach on weak returns and put away easy overheads.

3. EQUIPMENT

A) FACILITY REQUIREMENTS

To conduct wheelchair lessons or competitions, the facility must be “Accessible”. There are a number of key areas that are included for a facility to be fully accessible:

- **Court Accessibility:** Players must be able to get on and off the courts unassisted. There should not be any steps, steep inclines, or unpaved ground hindering the entrance. Doorways and gates must be wide enough to accommodate a wheelchair. The minimum requirement is 34 inches (which accommodates an ‘everyday’ chair). Preferably, the entrance can be wide enough to allow a cambered tennis chair as well (47 inches).
- **Court Surfaces:** Wheelchair tennis is played on all court surfaces. “Softer” surfaces such as clay or grass may require more effort to maneuver. Due to the use of the second bounce wheelchair tennis is often played beyond typical court boundaries, therefore ensure that there is ample back and side court spacing available for players to maneuver.
- **Washroom Accessibility:** Washrooms should also be accessible with the same ‘everyday’ chair entrance requirements. This includes the size of the bathroom stalls. A support bar in the stall is a good idea as well.
- **Shower Accessibility:** Showers should have a chair inside and faucets should be low enough to reach from a seated position.

B) ADDITIONAL EQUIPMENT

<p>STRAPS</p>	<p>Straps act as ‘supplemental muscle’ and perform the job disabled muscle would usually do. Straps can enhance balance and improve mobility by keeping weight centered:</p> <ol style="list-style-type: none"> 1. Chest & Waist straps: These can improve balance and sometime confidence but hinder reaching and rotation movement if not properly adjusted. 2. Leg straps: A strap around the thighs or just above the knees will prevent the legs from spreading and keep the body moving as a unit and in front of knees on shins to keep the legs back. 3. Foot straps: These will keep the feet securely on the footpad when turning or having leg spasms.
<p>RACQUETS</p>	<p>For beginning players, here are some racquet recommendations:</p> <ul style="list-style-type: none"> • Lightweight racquet (nothing over 10 ounces). • Oversize frames (100-110 square inches) can make contacting the ball easier • Smaller than required grip size allows for some contact on the wheel when pushing. • With wear on the grips due to contact with the wheel, a good supply of grip over wrap is a good idea.

FIGURE 3: Additional Equipment

TAPE

For Quad players with an impairment to their racquet hand, the racquet may be taped to their hand. Here are a few recommendations for taping:

- 1) Use athletic tape that is at least 1 ½ inches wide (not hockey tape because it can cut into the skin too easily).
- 2) For a new player tape using an Eastern or Semi-western forehand grip. This is a good starting point but be patient and try different grips to suit the individual. DO NOT tape the racquet handle up the wrist for support. If someone needs extra wrist support try a brace from a drugstore or wrap tape around the wrist a few times.
- 3) To affix the racquet to the hand start the tape by wrapping it around the wrist once clockwise (it is more comfortable for the player to wear a sweatband) then tape up across the pinky finger and around the racquet handle and back down around the wrist, repeat this taping motion over all the fingers going around the wrist each time. The racquet should be snug and should not slide, however please be sure circulation has not been hindered.
- 4) Take the roll of tape and wrap around the wrist and hand 2-3 times with the sticky side out (this is to ensure good traction on the push rim). Check periodically to ensure the tape is remaining snug, if it loosens add another layer over the existing tape pulling it tight as you wrap.



EQUIPMENT FOR HEAT

For quad players with internal temperature regulation difficulties, equipment to help handle hot weather conditions is required:

- Water bottles
- Spray bottles
- Hats
- Lightweight and light colored clothing are all good options.



C) THE CHAIR

In general, **all** wheelchairs can be used when first learning wheelchair tennis however, it is recommended to use a wheelchair designed for tennis as soon as possible. Some Provinces have chair loan programs so the initial purchase of a tennis chair is not always required.

Once the player intends to commit to the game, use of a rigid frame sport wheelchair is recommended. These chairs come in 3 wheel and various types of 4 wheel models. They dramatically increase the players' ability to maneuver.

Anatomy of a chair:

FIGURE 4:

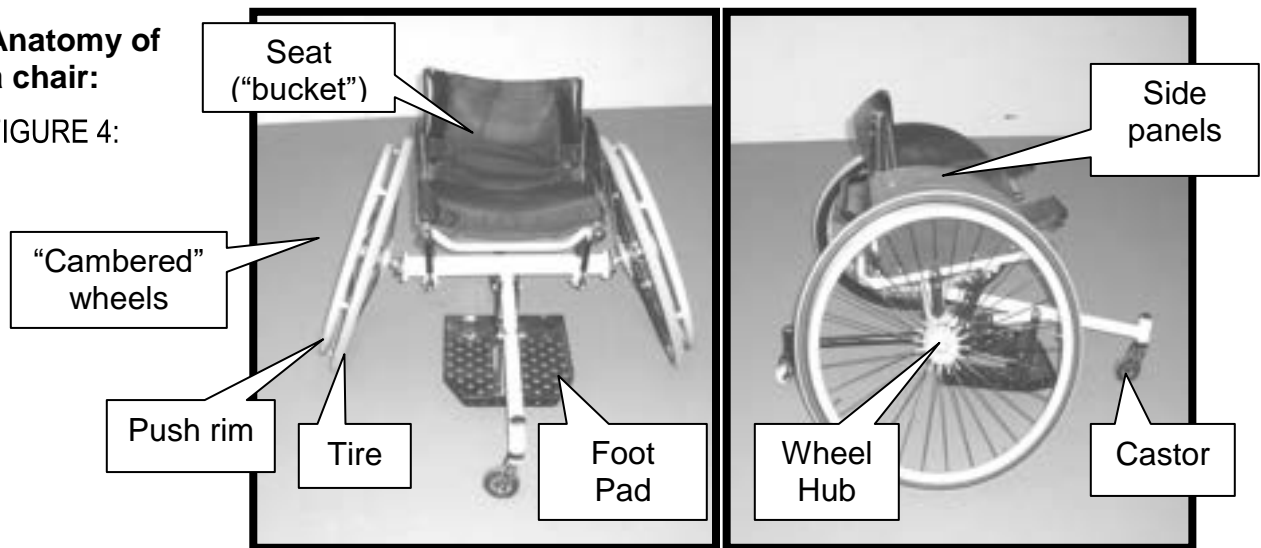

WHEELS	<ol style="list-style-type: none"> 1. Preferably lightweight and rigid 2. The more the wheels are 'cambered' (angled with the top of the wheel more in towards the player and the bottom more out) the more maneuverable and stable the chair. 16-22 degrees is recommended
TIRES	<ol style="list-style-type: none"> 1. Non-marking 2. High Pressure (tires should be kept fully inflated) 3. 24-26 inches in diameter and 1 inch wide
CASTERS	<ol style="list-style-type: none"> 1. Approximately 3-4 inches in diameter (10-12.5 cm). Larger casters will slow the ability to turn, smaller may not roll smoothly and 'flutter'. 2. High density (roller blade caster) 3. Not too thin (they may damage the court)
CHAIR	<p>The following adjustments increase speed, mobility, and balance: <i>*Note: with all adjustments personal preference and disability should be considered.</i></p> <ol style="list-style-type: none"> 1. Slant seat downward for more stability (lower in the back of the seat) 2. Adjust seat so elbows are close to top of wheel and palm of hand is level with the centre of the wheel hub for optimal pushing 3. Weight Distribution: Find the best balance between maneuverability and stability <ul style="list-style-type: none"> • Adjust weight towards axles for quicker movement. (chair becomes 'tippy') • Adjust weight forward to increase stability and a quicker start • The feet could be moved more under the body 4. Side panel can be added to reduce sideways movement



COACHING NOTE: There is no single way to set up the players' chair. The process of adjusting for optimal position is an ongoing process. The general rule is to make small adjustments over time to avoid major changes in balance.

4. RULES OF WHEELCHAIR TENNIS

The game of wheelchair tennis follows the same rules as able-bodied tennis as endorsed by the International Tennis Federation (ITF) with the following exceptions:

A) THE TWO BOUNCE RULE

The wheelchair tennis player is allowed two bounces of the ball. The player must return the ball before it hits the ground a third time. The second bounce can be either in or out of the court boundaries.

B) THE WHEELCHAIR

The wheelchair is considered part of the body and all applicable rules which apply to a player's body shall apply to the wheelchair.

C) THE SERVICE

The service shall be delivered in the following manner:

- i. Immediately before commencing the serve, the server shall be in a stationary position. The server shall then be allowed one push before striking the ball.
- ii. The server shall throughout the delivery of the service not touch with any wheel, any area other than that behind the baseline within the imaginary extension of the centre mark and sideline.
- iii. If conventional methods for the service are physically impossible for a quadriplegic player, then the player or an individual may drop the ball for such a player. However, the same method of serving must be used each time.

D) PLAYER LOSES POINT

A player loses the point if:

- i. The player fails to return the ball before it has touched the ground three times.
- ii. Subject to the rule below, the player uses any part of his feet or lower extremities as brakes or stabilizers while delivering the service, stroking a ball, turning or stopping against the ground or against any wheel while the ball is in play.
- iii. The player fails to keep one buttock in contact with his wheelchair seat when contacting the ball.



COACHING NOTE:

The rules of wheelchair tennis are designed with very few differences to stand-up tennis so wheelchair and stand-up players can compete with and against each other.

E) PROPELLING THE CHAIR WITH THE FOOT

- i. If due to lack of capacity a player is unable to propel the wheelchair via the wheel then he may propel the wheelchair using one foot.
- ii. Even if in accordance with the rule above a player is permitted to propel the chair using one foot, no part of the player's foot may be in contact with the ground:
 1. During the forward motion of the swing, including when the racquet strikes the ball;
 2. From the initiation of the service until the racquet strikes the ball
- iii. A player in breach of this rule shall lose a point

It is legal for a player to hit a return, fall out of his chair and then get back into his chair to make the next return.

F) WHEELCHAIR/ABLE-BODIED TENNIS

Where a wheelchair player is playing with or against an able-bodied person in singles and doubles, the Rules of Wheelchair Tennis shall apply for the wheelchair player while the Rules of Tennis for able-bodied tennis shall apply for the able-bodied player. In this instance, the wheelchair player is allowed two bounces while the able-bodied player is allowed only one bounce.

G) POWER WHEELCHAIRS

Wheelchair tennis can be played by individuals using power chairs. Players compete in the quad division and must meet minimal classification requirements to be eligible.





CHECK YOUR UNDERSTANDING

Reflect on these questions regarding the section you have just read.

WHEELCHAIR TENNIS

What year did wheelchair tennis begin? Who governs wheelchair tennis in Canada?

What are the 4 basic levels of injuries (each starts with a letter)?

What is your personal “integration philosophy”? How will you accomplish it?

List 3 principles you must keep in mind when communicating with wheelchair players?

1. _____

2. _____

3. _____

List 3 key areas of a tennis facility that must be modified to make it ‘fully accessible? What characteristics must each area have?

1. _____

2. _____

3. _____

What are straps used for?

Describe the following terms:

1. “Push rim”:

2. “Camber”:

List 2 key rules that wheelchair tennis has that is different from stand-up tennis?

1. _____

2. _____



HELPING PLAYERS TO LEARN TENNIS

1. APPROACHES TO LEARNING THE GAME

(This section adapted from Tennis Coaches Australia Developmental Coaches Manual © Louis Cayer, Wayne Elderton, 2001)

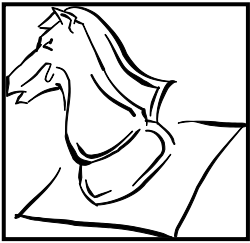

When it comes to technical and tactical skills, there are different ways to teach tennis. Internationally, the trend in tennis coaching is moving to a more "Game-based" approach. In this approach, the fun of playing tennis is introduced right from the beginning by re-creating playing situations adapted to the level of the players. As they play, students learn they must accomplish certain tasks to be consistent or win more points. Students discover what to do (tactics) by being placed in situations that promote problem-solving and decision-making.

Technical skills are then presented to implement the solution to problems encountered in these situations. With such a direct link to playing tennis, all the skills learned in the lesson transfer easily into match play. This approach promotes students being active and fully involved in their learning process. With children, the situations are adapted to their size and skill level by using skill development games.

This approach will help you begin a challenging and enjoyable journey with your students. It will provide plenty of tools and ideas for activities that meet your student's need to learn, exercise, and **play the game!**



COACHING NOTE:

The concept is simple: "*Get people to play tennis and help them to learn to play better.*"

A) COACHING EVOLUTION:

Considering the nature of tennis, and the types of skills used, let's contrast the two primary philosophies used to coach tennis world-wide, the "**Model**" approach verses a "**Game-based**" approach.

i. The "Model" approach

The traditional way tennis has been taught is with a "Model" approach. The *philosophy* of this approach was simple: Teach the best technical model for each stroke to help the students play the best tennis possible. Motor skills were the priority.

The *methodology* of the approach was also simple: Demonstrate the model stroke and then have the students reproduce the model stroke. In lessons, students were immediately introduced to an 'idealized' version of a stroke (e.g. the forehand). Learning the 'proper' grip, preparation, swing, and follow-through, were all preconditions to playing tennis. These were typically learned in a controlled environment with the coach lightly feeding the ball to the student. *Technique* was the main goal, *tactics* were presented later, once a player learned how to hit the ball.

The challenge in this approach is that conforming students to a “one size fits all” stroke hurts individuality and the ability to adapt technique to the situation at hand. This is critical for wheelchair players.

ii. A Game-based Approach

The Game-based approach uses the word "game" to emphasize the idea of *playing* rather than reproducing a technical model. The idea behind the approach is that since tennis is a *game*, students need to learn how to *play*. The fun of playing is why people take up the sport.

The *philosophy* of the approach is that playing is not just a technical challenge but a tactical one as well. The tactics of the game dictate the technique of the game. In other words, one needs to know **what to do** before being taught **how to do** it. Cognitive skills become equal in priority to motor skills.

FIGURE 5: Model vs Game-based Approach

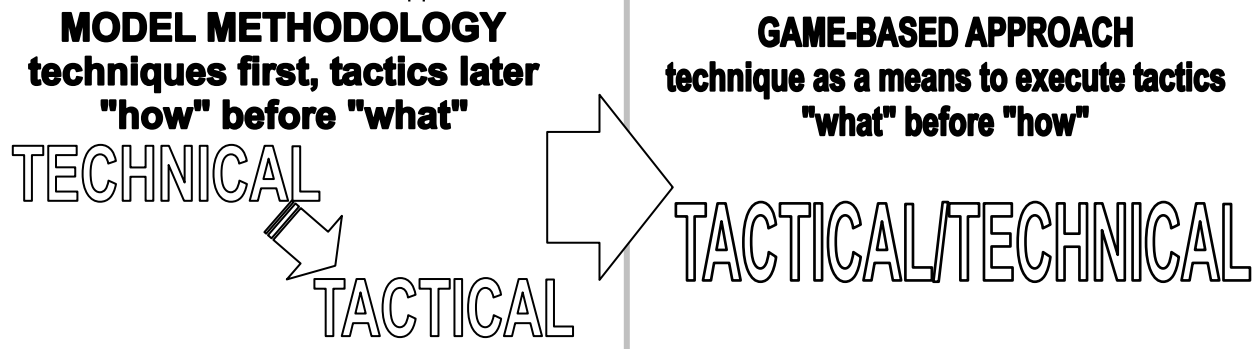

The *methodology* of the approach is to structure a progression of situations to develop the competency of playing tennis. Players are taught how to make tactical decisions and learn technical skills as solutions to solve problems on court. Technical skills are learned in the context of playing.

The term "Game-based" however, doesn't mean that lessons involve students just playing tennis points. In this approach, the *game* is broken down into specific, frequently encountered situations, adapted to the student's level. Once those situations are identified, they are presented to the student as problems to solve. The coach then sets-up drills to groove the technical skills required to achieve the desired outcome. This approach allows students to maintain the feel of playing while getting the appropriate repetition to develop the perceptual motor skills of tennis.

For example, one of the first playing situations a beginner needs to master, is how to rally. Exchanging the ball with a partner is a source of great enjoyment for most players. Instead of copying a model, students can be placed in situations where they need to rally with each other in a 'small scale' version of tennis at Mid-Court. This situation will create many challenges for the beginner. One key problem is making the appropriate contact with the ball. To solve the problem, they will be led by the coach to discover that contacting the ball in front of them, with the strings of their racquet facing their partner, helps to centre the ball and send it back to their partner.

2. DEVELOPMENT PATH

What tactics and techniques should I teach? Is there an order that works best? Tactical & technical skills can be presented in ways that ensure success, fun, and maintain a Game-based approach. A 'development path' can be created by progressing through the **Development Programs** and appropriate modified courts and equipment.

To maintain the feeling of playing tennis (keep the game intact as much as possible), avoid breaking it down into many technical parts right away. Specifically designed Development Programs allow a coach to *evolve* playing skills. They sequence frequent situations players commonly encounter and order skills from more simple to complex. This presents skills as a progressional series of problems to be solved rather than strokes to be reproduced.



COACHING NOTE:

Use tactical themes and "Situations" rather than strokes to plan programs and lessons.

In addition to Development Programs, another very effective way to maintain the experience of playing the game, is to modify the size of the court and the ball used. Around the world, this is called 'ROG' (Red, Orange, Green). By scaling the court and using a modified ball, students experience the fun and excitement of playing tennis right away. Progressing through the various stages of ROG allows skills to be 'grown' as the level of the students improve.

A) DEVELOPMENT PROGRAMS

To fully learn tennis, players progress through 4 basic "programs". Each program builds a solid foundation of skills in a **tactical** framework. Each successive program adds more tactics and skills step by step.

1. Rally Program: The most basic way people play tennis is to rally. A rally is where players exchange the ball cooperatively. Even advanced players must master cooperatively warming-up with partners. Exchanging the ball is fun, and is the first situation to master in a Game-based Approach. The goal of this program is to "*Create a comfort zone*" which is an imaginary area around a player where they can receive and send a ball with control. To develop this skill, it is important that players cooperate. This will increase repetition, skill development and fun! It also equips them to practice without a coach. Players in this program learn to:

- Rally using groundstrokes
- Rally using volleys (volleys to groundstrokes)
- Serve and start a rally
- Return and continue a rally

2. Reception Program: In this program the goal is to, "*Expand the comfort zone*". Players are taught to send the ball back consistently when the ball received gets more challenging. Players must be able to maintain a rally when:

- Receiving wider, shorter, higher, deeper, or faster balls when using groundstrokes (reception of spins would be covered at higher levels).
- Receiving wider, lower, higher, and faster balls when using volleys
- Receive overheads
- Returning wider and faster serves

This program is critical to develop the decision-making skills required to receive the ball properly (Concentration, ball judgment, racquet/body preparation, and mobility to move to the right or left, up or back, etc.)

It is important that this program is positioned right after the rally program since, whenever a player sends a ball, they must first receive one (except when serving). The quality of the reception will directly affect the quality of the projection. Players must be able to set-up for a shot and decide what to do before sending the ball. By focusing on reception, this program lends itself to very dynamic drills to keep players challenged and active.

3. Projection Program: In this program the goal is to, "*Challenge the opponent's comfort zone.*" Players learn to send the ball with more variation.

- Send groundstrokes wider, higher, shorter, deeper, faster (introduce topspin & slice at the start of the intermediate level)
- Send volleys wider, deeper, shorter, faster (introduce underspin at the start of the intermediate level)
- Send overheads wider, faster
- Send serves wider, faster (introduce slice & topspin at the intermediate level)
- Send returns deeper, and with more accuracy and speed

In a Game-based Approach, sending a ball isn't a matter of copying the 'model' stroke. Players are put in situations where they must creatively solve the problem of how to control the ball. For example, the situation may call for them to control the direction of the shot. The students would discover, or be lead by the coach to discover, that the racquet face angle at contact controls direction. In order to achieve this, some students may change body position, some may take the ball at different impact points (earlier or later), etc. Instead of trying to reproduce a model stroke, they would learn how to use their technical skills to accomplish tasks by controlling the ball's height, distance, direction, speed and spin.

4. Tactical Program: The first three programs develop technical skills in the tactical situations of rallying, maintaining a rally, and challenging an opponent's rally. The goal of this program is to present the tactical elements that allow a player to win more points or be more consistent by constructing strategies and tactics including Phases and Zones:

Phases of Play: The relationship between reception and projection is trained so the player can respond appropriately to competitive situations. Using specific decision-making drills, players learn to quickly identify the difficulty of a situation and choose an effective solution.

- Rally: Receiving a neutral ball and remaining neutral
- Defense: Receiving an difficult ball and sending back a ball that neutralizes an opponent
- Attack: Receiving an easier ball and taking advantage by sending a more challenging one back.
- Forcing: Receiving a neutral ball and sending a challenging shot back.
- Countering: Receiving a difficult ball and taking the risk to send a challenging shot back

Zones of Play: A player's location in one of the 4 different "Zones" affect decision-making and technique. The 4 zones are:

- Baseline
- 3/4 Court
- Mid-Court
- Net

B) RED, ORANGE, GREEN TENNIS (ROG)

ROG is a system of modifying the court size, ball, and in some cases the racquet, to allow for earlier success and easier play. This colour-coded system is used around the world to introduce the game to starter juniors, adults and wheelchair players.

Scaling the game allows starter players learn the 'whole game' (rather than parts) by mastering a scaled down version. Players can grasp the 'big picture' of how to play. They experience success quickly which builds a foundation for the future and motivates them to strive to learn the full court game.

ROG has 4 stages:

- Red Tennis
- Orange Tennis
- Green Tennis
- Yellow Tennis

Red Tennis:

Playing sideways across the court on a 36 x 18 foot court (or serviceline to serviceline) is an easier distance to master. Red Tennis uses an oversized foam or felt ball for easier visual tracking and control.

Note: Coaches may also use a step before Red tennis where players are a very short distance apart ('Micro-Tennis' or called 'BlueTennis' in some countries)

Red Court Set-up

By splitting the court into 6, Red Courts (for training, court width can be varied), 12 players can be easily accommodated on one regulation court. Stringing a rope as the net can work just as well as using official Mini-nets.

FIGURE 6: Red Court Set-up

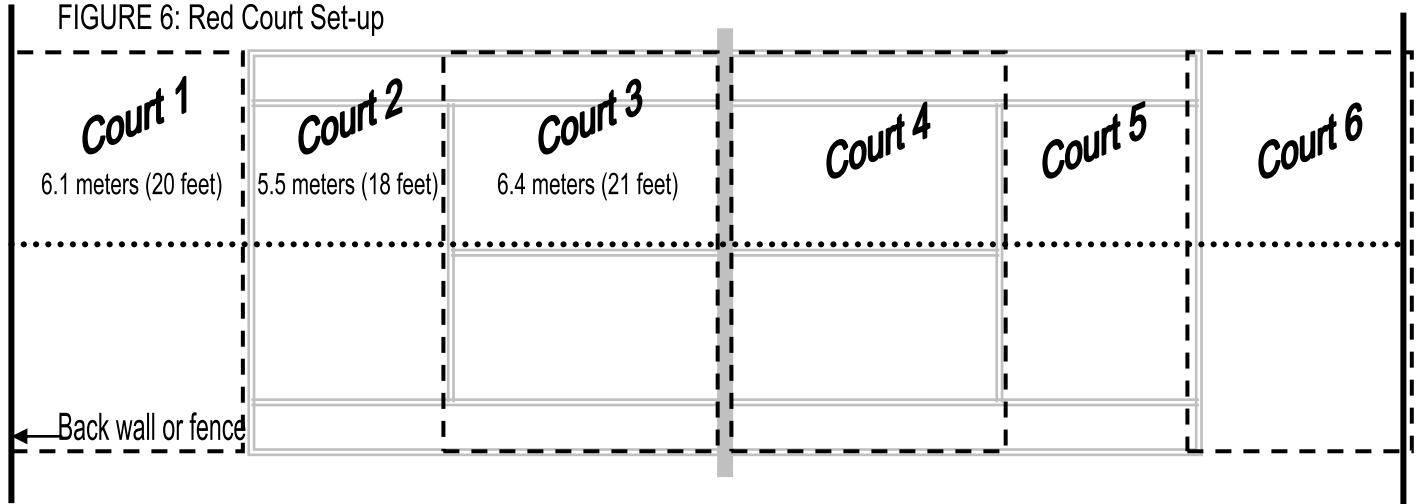

Alternative set-up.

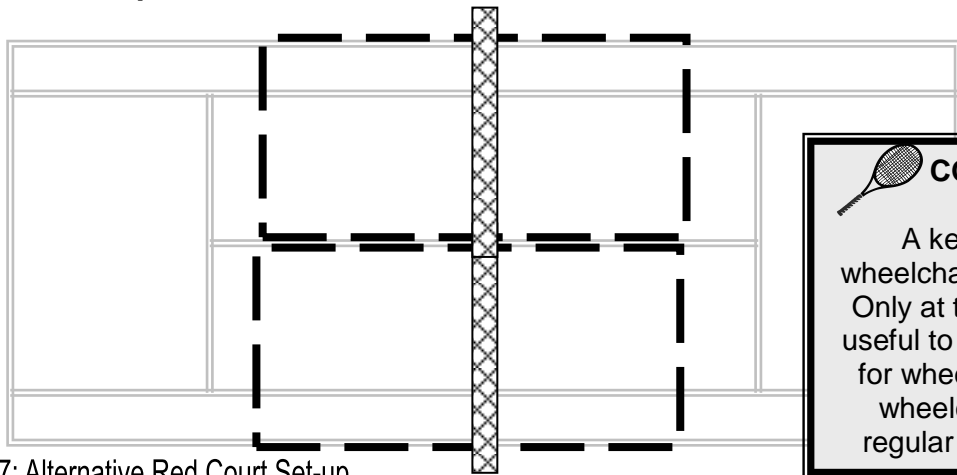



FIGURE 7: Alternative Red Court Set-up

 **COACHING NOTE:**

A key goal in developing wheelchair players is **Integration**. Only at the very lowest level is it useful to have specialty programs for wheelchair players. Include wheelchair players into your regular programs and lessons.

Orange Tennis:

Play is from in-between the serviceline and baseline. A low-compression ball is used. Technically, how to increase ball speed is presented at this stage as well as basic grip changes to receive tougher balls and send more accurate balls (and spins at the intermediate level).

An Orange court is $\frac{3}{4}$ the size of a full regulation court. The length is 60 feet long x 21 feet wide. Two Orange practice courts can be set-up on one regulation court to accommodate more players. There are two variations of the Double Practice Court.

1. Two narrow-width courts on one regulation court. After creating an Orange Court baseline, no additional lines are required for this configuration.
2. Two Full-width practice courts on one regulation court. Additional lines are required for this set-up. The Orange Court sidelines are placed just outside the net post.

FIGURE 8: Orange Court Set-ups

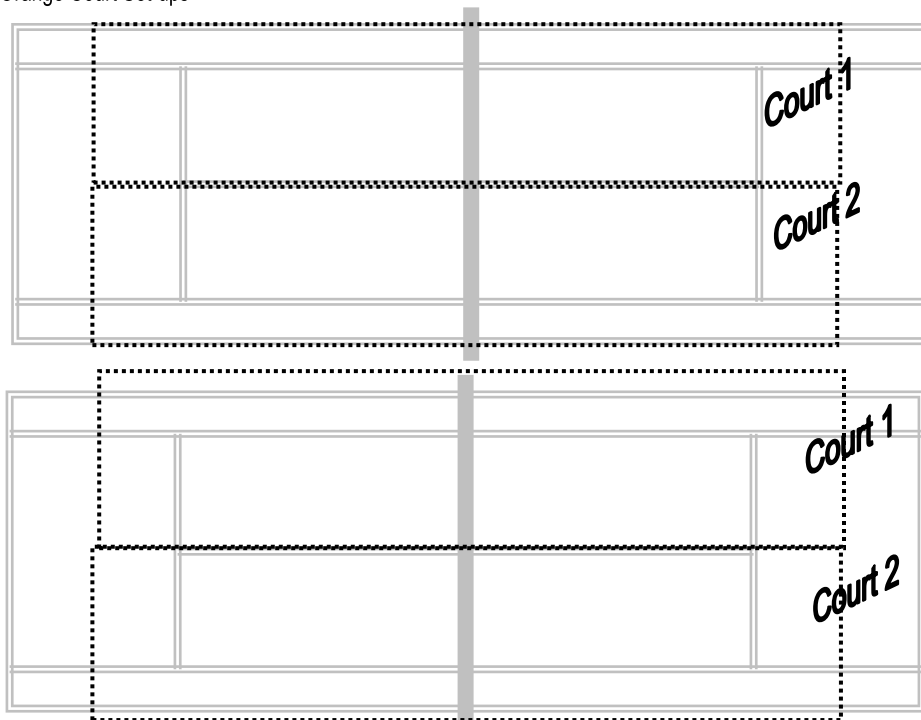

Orange Competition Set-up

For competition (or training that requires the whole court), the full Orange Court is set-up on one regulation court.

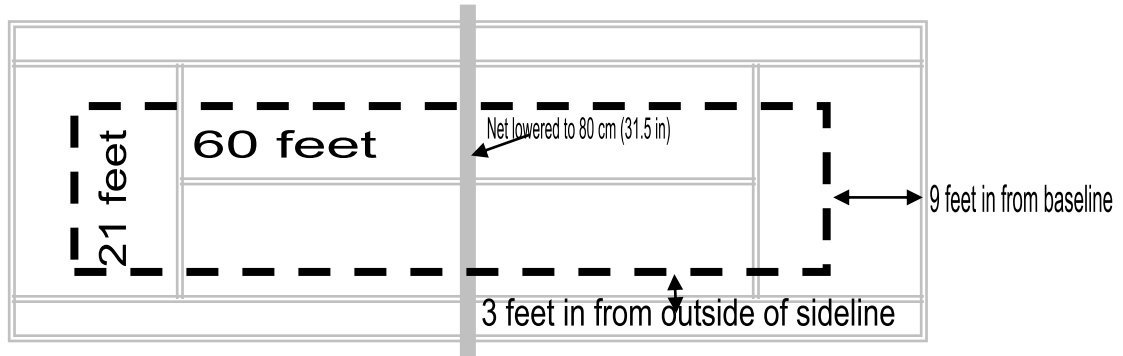

FIGURE 9: Orange Court Competition Set-up

Green Tennis:

Players play on the whole court. The first step is to play on the full court but use a Green 'transition' ball. The final step would be to use a regulation ball. Technically, all fundamentals should be presented. Spins would also be introduced at the intermediate level.

ROG Tennis is an effective way to ease players into wheelchair tennis. Red tennis can be easily played in a gym or even a parking lot.



In ROG, court size, balls, racquets and even scoring can be modified to suit the level of player.

FIGURE 10: Programs & Stages

BEGINNER (.1) to INTERMEDIATE (2.5) DEVELOPMENT PATH

This chart outlines the basic components of a tactical & technical tennis development plan to take players from beginner level to intermediate.

In each Program and Length, skills are developed on both sides (forehand & backhand) and in all
3 STROKE FAMILIES: -Groundstrokes -Volley -Overhead (serve & smash)
 Using the **5 BALL CONTROLS:** -Height -Direction -Distance -Speed -Spin*
 (*Spin would be covered in the 2.5+ level)

DEVELOPMENT PROGRAMS

PROGRESSIVE TENNIS STAGES

Rally Program: (.1-1.5)
"Create a comfort zone" where the player can comfortably control the ball and exchange it with a partner.

Reception Program: (1.5-2.0)
"Expand the comfort zone" so the player can receive more challenging balls and still maintain a rally.

Projection Program: (2.0-2.5)
"Challenge an opponent's comfort zone" by sending the ball in a more challenging way.

Tactical Program: (2.5+)
 Improve consistency or win more points by employing:

- *Phases of Play:* (Rally, Defend, Attack, Force & Counter)
- *Zones of play:* (Baseline, 3/4 Court, Mid-Court, Net)

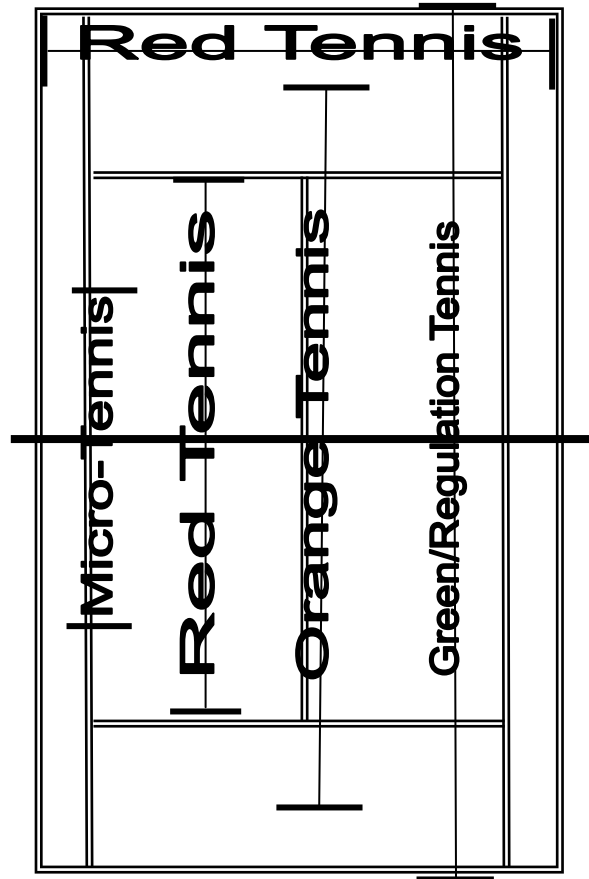

PROGRAMS OR LENGTHS?

A coach has the option to progress students through both 'Programs' and 'ROG Stages'. For example, for children they may remain at the Red Stage for a full year and progress through all the programs (A). For beginner adults, they may stay in the rally program and progress through all the Stages in a course (B). For an intermediate specialty course, they may stay at full court and cover a projection program on just groundstrokes (C). Coaches may use any combination when planning, as long as students ultimately progress through all the programs and Stages.

	RALLY	RECEPTION	PROJECTION	TACTICAL
RED	B A →	A →	A →	A →
ORANGE	B			
GREEN	↓ B		C	

3. BASIC TACTICAL SITUATIONS

In this section we will introduce some key concepts for both Singles and Doubles Tactics for wheelchair tennis. Wheelchair tennis is still primarily considered a baseline game. Although the game is slowly being transformed into an all court game, players will typically spend 90% of their time on the baseline.

A) SINGLES

For introductory players, tactics are very simple to understand, but hard to do. Here are a few basic tactics that can be turned into lesson themes or drill topics:

Keep the ball in play

- Aim for 'low-risk' areas on the court (crosscourt or in the centre)
- Clear the net by 1-2 meters to avoid net errors
- Force opponent to make errors through sustained pressure (consistency).

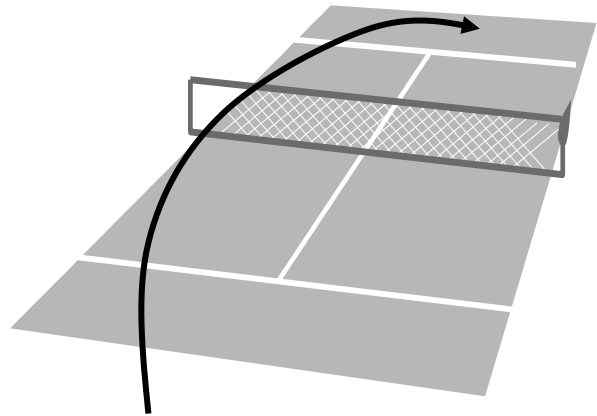

Place the ball

- Place the ball to the weaker side: (e.g. backhand)
- Hit to the sides: (Going for the sides of the court to pull the opponent off the court is a good option when a player receives a weak ball in the centre of the court.)
- Hit behind the opponent: (Because of the difficulty of reversing direction once a player is in a turn, this is a very effective tactic. Aim to hit behind the opponent while they are recovering. It forces a player to execute an out turn to get to the ball, thus forcing the player into a more defensive deep court position.)
- Hit into the opponent's body: (We have mentioned the difficulty of moving out of the way of the ball, thus being able to exploit this effectively is useful.)
- Make the opponent move forward with a drop shot: (The Drop Shot is an effective, yet underutilized option. It forces a player into the net where they are most vulnerable. It takes advantage of limited mobility, quickness and often deep positioning of players.)

Top wheelchair players are now pushing the game further into the court, playing shots off the first bounce, creating angles and thus forcing their opponents to play closer to the baseline. Not only are they moving in, but power is being added to the game as well. As the game moves forward and becomes more power based so will the versatility of shots required and angle opportunities. We are seeing a new era of wheelchair tennis take shape, although the variety of styles and approaches still remain limited.

These particular tactics are very general and can be used for doubles as well.

B) DOUBLES

Many feel that the Doubles game is the most suited for wheelchair tennis, considering mobility and court coverage limitations of the singles player. Typically you find that in doubles the rallies are longer, the winners fewer, and the points often more exciting. The traditional stand-up approach to Doubles (closing the court by attacking the net and thus creating angles and openings), does not directly apply to wheelchair tennis.

FIGURE 11:

Two Back Starting Positions

- It is recommended that beginning to intermediate players play with both players positioned behind the baseline in the two back position. Height and reach limitations make both players at the net relatively susceptible to being passed but two players back can cover the whole court (especially with two bounces).
- It is recommended that servers start one chair width behind the baseline on their half of the court (further towards the sideline than the typical singles serve position). Servers partner should be on the other side and further back than the server to get momentum going to play the ball.
- The returner should start near the baseline and singles sideline. The returner's partner is positioned on their side of the court and further back to begin momentum once the play begins.
- Players cover each half of the court as a team and avoid leaving any 'gaps' on the sides or middle. They attempt to create angles and openings by forcing their opponents back or wide. Once an opportunity is created, players can attack either the middle or the angles.

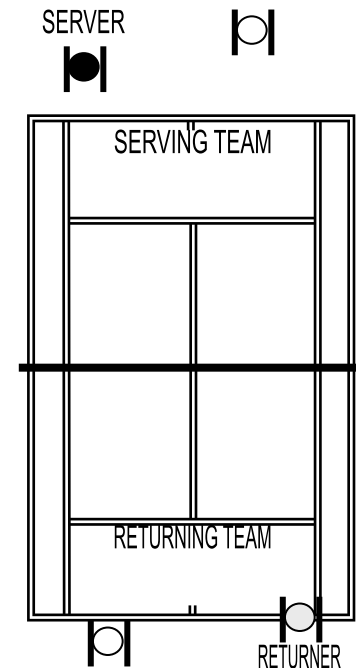

FIGURE 12:

One-Up-One-Back Positions

- More advanced players are now beginning to include net play with great success.
- With the **One-Up-One-Back** formation the net player makes circular patterns moving forward as the ball is hit towards the opponent and back as the ball is returned.
- The circular movements allow the player to maintain momentum in the chair.
- Typical positioning for the net player is around the service line areas.

Continuous Motion and Communication

- It is important that both players maintain continuous motion throughout the point whether in a *Two-Back* or *One-Up* formation (accomplished by circular movements).
- Communication between players is also important.

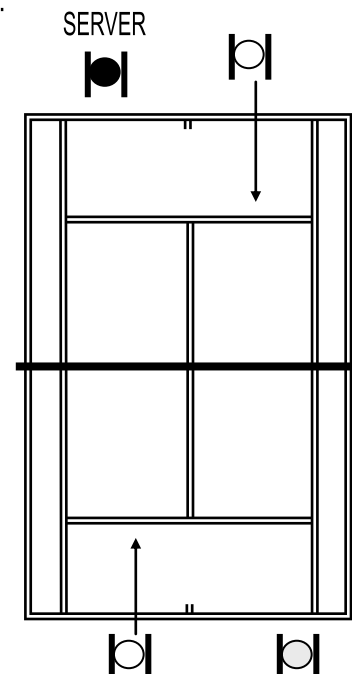



CHECK YOUR UNDERSTANDING

Reflect on these questions regarding the section you have just read.

HELPING PLAYERS LEARN TENNIS

Tennis coaching is evolving from what approach, to what approach?

What is the *philosophy* and *methodology* of the traditional 'model' approach?

What is the *philosophy* and *methodology* of a Game-based approach?

What are the 4 stages of ROG and the accompanying court size?

1. _____
2. _____
3. _____
4. _____

What is the advantage of progressing a player through the 4 Stages of ROG and using a Game-based approach?

List the two most common singles tactics employed in introductory wheelchair tennis?

1. _____
2. _____

What are the two most common starting positions used for a doubles team in wheelchair tennis?

1. _____
2. _____



TECHNICAL DEVELOPMENT

1. DEVELOPING TECHNIQUE:

One of the main objections to a Game-based Approach is the fear that technique will be lost or mishandled. The false concept traditional coaches had was that, *the model was the definition of correct technique*. This has been consistently proven false since players who don't conform to the model still play with great success. But if it is not the model, then what? What is 'correct' technique for a shot if wheelchair players must constantly adapt their stroke technique to the situations they are in?

For example, in a Model based approach, a certain style of Racquet work preparation was advocated (traditionally: "Take the racquet back pointing to the back fence", or more recently, "Loop the racquet up and around").

A) PRINCIPLE BASED TECHNIQUE

To develop effective technique, it is the **principles** that must be identified. Preparations can occur with many different styles (direct, loop up, elbow lead, etc.) Any style is fine provided the preparation allows the player to adjust to differences in the situation. The *principle* is that every preparation must allow the player to receive balls at different heights and speeds. The specific situation determines what is 'correct' or not.

In tennis, technique needs to be adapted to the situation. As a result, tennis technique becomes **principle-based** rather than **model-based**. In other words, coaches need to know and teach technical principles that are true in all situations and still allows players to adapt.

B) DEFINITION OF TECHNIQUE

As mentioned previously, reproducing the 'ideal' stroke is not the goal of technique. Technique is only a tool used to play the game. Since playing requires adapting efficient movements to a situation, as well as achieving a desired outcome (what is the use of moving properly if it doesn't win more points?), technique takes on a "two-fold" definition. The first component is "**Effectiveness**" and refers to what the Ball and racquet do. The second is "**Efficiency**" and refers to what the player's chair and body does.

Using the principles of Effectiveness and Efficiency, a coach has the tools to teach students how to be technically successful at tennis. They can be applied to any situation and every level. Students can become very effective and move with biomechanical efficiency without being constrained to an idealized version of strokes. Rather than mishandling technique, a Game-based Approach can be used to teach practical, relevant, and effective technique.

FIGURE 13: Technical Development Chart



EFFECTIVENESS:

Effectiveness is about the **ball**. This is what creates the outcome of the shot technically. There are only five ways the ball can be manipulated in tennis. These make up the **5 Ball Controls**:

-Height -Direction -Distance -Speed -Spin

Players must learn how to receive variations of these (receive balls on the forehand or backhand side, deeper, shorter, higher, lower, etc.) and send variations of these (project the ball down-the-line, crosscourt, deep, short, with topspin, etc).

All of the 5 Ball Controls are determined by the **P.A.S.** Principles at the Impact point.

- **Path of racquet**
- **Angle of racquet**
- **Speed of racquet**

Every shot in tennis is the result of a combination of a certain racquet angle, path and speed.

EFFICIENCY:



Efficiency is about the player's **body, chair & racquet**. To be considered correct, these movements must be:

- Biomechanically efficient (will not waste energy or lead to injury).
- Allow for long-term development (builds a future foundation so players can hit as hard and accurate as required to be successful at the highest level). Efficiency allows the ball control to happen consistently and take effectiveness to higher levels (e.g. a player may be able to control the ball at low speeds but to reach a higher level they must receive and send balls at higher speeds to win).
- Allow for individuality (as long as the previous two principles are maintained)

The 5 Fundamentals are the key technical principles that are required for efficient strokes. Keep in mind that the priority would be for players to time the ball well so Impact point would be the most important principle.

- **Grip**
- **Set-up**
- **Impact point**
- **Hitting Zone**
- **Recovery**

In addition, to capture the stroke actions in a simple way, each stroke family has a key feeling associated to performing strokes in a neutral phase.

- **Groundstrokes** can be described as a **"Pushing"** action
- **Serves** can be described as a **"Throwing"** action
- **Volleys** can be described as a **"Catching"** action

2. TECHNICAL CONSIDERATIONS

In principle, the fundamentals of racquet work, biomechanics and ball control are the same for wheelchair players as stand-up tennis players. The main difference is that wheelchair players have **less time** to execute strokes. The combination of mobility limitations and the fact that the racquet hand is engaged in maneuvering the chair makes it difficult to prepare early.

A) BALANCE

Balance is an important element in tennis and it takes on an even greater significance in wheelchair tennis. In wheelchair tennis, balance is less a factor of footwork as it is a factor of the player's disability, and their ability to control their upper torso. Basically, players either have it or they do not, dependent on their disability. Upper body balance effects the players:

- Ability to reach and hit.
- Ability to 'recoil' the upper body after hitting or reaching for a shot, or while pushing.
- Ability to keep the torso upwards during the stroke.
- Ability to rotate the torso for generating more power.
- Ability to lean backwards and side to side.

To assist balance, players can employ three main strategies:

Controlling your head: The position of the head can 'lead' the direction a player wants to go. The position of the head can also inhibit movement if it is leaning too far or the wrong way.

Straps: These can be used to keep legs and torso in place and assist the 'recoil' once a player reaches out or leans to get a ball or push.

Grabbing the wheel: Another way to help balance is to use the non-racquet hand to grab on to the wheel for serves and forehands. This can give the player a sense of 'steadiness' and, if they pull on the wheel, initiate a good rotation.



The following are some specific technical points to consider regarding the 3 stroke families including specific balance issues:

A) GROUNDSTROKES

- **Grips:** All grips for tennis also work for wheelchair players. Coaches should guide players into grips that would work best for each individual. One additional grip required is the grip to hold the wheel and the racquet. Each player must find a grip that can maximize the contact point on the wheel and allow for a quick transition to stroking. Typically, beginner players can find good success using an eastern forehand or continental grip.
- **Balance & Stability:** It is acceptable for the player (right-handed) to grab the left wheel with their left hand for balance while performing groundstrokes. On forehands that require a player to reach forward, a player may lean on both knees with the left forearm. For extra rotation, a player can pull back on the left wheel on forehands

B) SERVE & OVERHEAD

1. **Toss:** Higher injury level players will not be able to toss the ball directly over or behind their head.
2. **Serve position:** It is recommended the server start one chair width behind the baseline so they can move towards the return without being too far into the court.
3. **Impact point:** On overheads, the player must maneuver to create an impact that is slightly forward of the chair. Taking the ball on the bounce or chasing it down and hitting 'over the shoulder' when facing the back wall is another option. With 4 wheel chairs (chairs with an additional wheel in the rear) a short backward roll is also possible.
4. **Balance & Stability:** A technique that can improve stability is to grab or pull back on the left wheel with the left hand immediately after the toss on the serve.

C) VOLLEYS

Wheelchair players can come into the midcourt and net to take advantage of weaker shots and finish points. Keep volley movements simple and compact. A short 'catching' action is recommended.



COACHING NOTE: In wheelchair tennis, it is critical to develop mobility skills at the same time as racquet skills. This is different than developing a stand-up player where racquet skills are often learned with little movement.

3. BALL FEEDING

Feeding is delivering a ball to a player in order to provide repetition on specific skills. Feeding is an important aspect of player development since simply playing tennis may not provide the required repetition to develop skills in a timely manner. Keep in mind feeding can be done by the coach to students, or students to each other.



A) “DEAD BALL” & “LIVE BALL” FEEDING:

It is important for instructors to understand the two key types of feeding:

Dead Ball Feed: Is when a ball is delivered to a player from a static start (e.g. Feeding from a basket). The feeder can drop the ball, toss it by hand, or send it with their racquet. The advantage of this type of feeding is being able to control how the ball gets to the student. The disadvantage is that it is unrealistic.

Live Ball Feed: Is when the ball delivered to the player is in play. For example, if a coach rallies a ball continuously with a player (in contrast to feeding from a basket), that is a ‘live’ ball. The advantage is that the ball received is realistic. The disadvantage is that the lack of control may mean there is less repetition on the specific skill being trained.

B) FEEDING RECOMMENDATIONS

When feeding balls to a player (either from a basket or rallying with the player), there are a few recommendations that can assist to recreate more realistic practice:

- **Frequency:** When basket feeding, allow more time between ball feeds to re-create the timing of two bounces.
- **Bounces:** The one bounce feed is typically easier for beginning players when starting at the service line area. Mix one and two bounces when playing from baseline to baseline.
- **Serves:** Some instructors chose to simulate the serve hitting from their knees. Another option is to serve from several feet behind the baseline (it more closely simulates the flight pattern of the ball).

C) DEVELOP SELF-SUFFICIENCY:

As with stand-up players, it is important for introductory wheelchair players to learn to feed and rally *with each other*. It is critical to empower them to be independent and self-sufficient enough to practice on their own. It is very tempting for an instructor to constantly feed players the ball because, “they can’t rally”. Obviously, they will not be able to at first however, over time, they will develop this critical skill. The sad truth is, an instructor can continually basket feed players in lessons and the players still can’t rally after many sessions. The act of rallying is the basis of tennis play and should be prioritized over feeding to make strokes with ‘good form’.



CHECK YOUR UNDERSTANDING

Reflect on these questions regarding the section you have just read.

TECHNICAL DEVELOPMENT

Describe the difference (and advantages) between 'model based technique' and 'principle based technique'?

What are the two main components of the 'two-fold' definition of technique? Define each one?

1. _____

2. _____

List the 5 Ball Controls and their *determining* factors?

1. _____

2. _____

3. _____

5. _____

List the three elements of *Efficiency*?

1. _____

2. _____

3. _____

Why is balance an important technical element in wheelchair tennis?

What key technical consideration would be important to keep in mind when coaching a quad player? (hint: grip)

Describe the difference (and advantages) between 'model based technique' and 'principle based technique'?



MOBILITY

Dr. Bal Moore, former coach of the US Olympic wheelchair team has said, “*Mobility is the single most important aspect of wheelchair tennis. It provides the base and transition for balance, timing, motion, and the execution of skills. This is perhaps the biggest difference between wheelchair and able-bodied (A/B) tennis.*”

Randy Snow, 10 time US Open wheelchair champion has added, “*Mastering mobility is probably the most important area in becoming a good wheelchair player.*”

Coaches need to know the framework and components of wheelchair tennis movement to develop players.

In order to maximize positioning for any shot, a wheelchair player goes through a "Mobility Cycle". The Cycle includes: The ‘Neutral Position’, ‘Maneuvering’ (the movement of the chair to position for the shot), ‘Preparation’ (setting up for the stroke & the stroke itself), and ‘Recovery’ (the chair movement to prepare for the next shot).

During the Mobility Cycle it is an important goal for the player to keep moving continuously. In this way, the laws of inertia and momentum can work for the player. A point may consist of many cycles linked together with the players’ movement flowing from one cycle to the next. This is preferred over repeated stops & starts.

**COACHING NOTE:**
It is critical that a player keeps moving continuously during a point.

FIGURE 14: Mobility Cycle



1. NEUTRAL POSITION

From the return of serve, or just after the serve, the cycle starts with the player in a Neutral Position with the body in balance to allow a quick start in any direction. The position requires both hands on the wheels for quick movement. During play the Neutral Position is dynamic with the player simply regaining balance and establishing good Contact Points after a stroke.

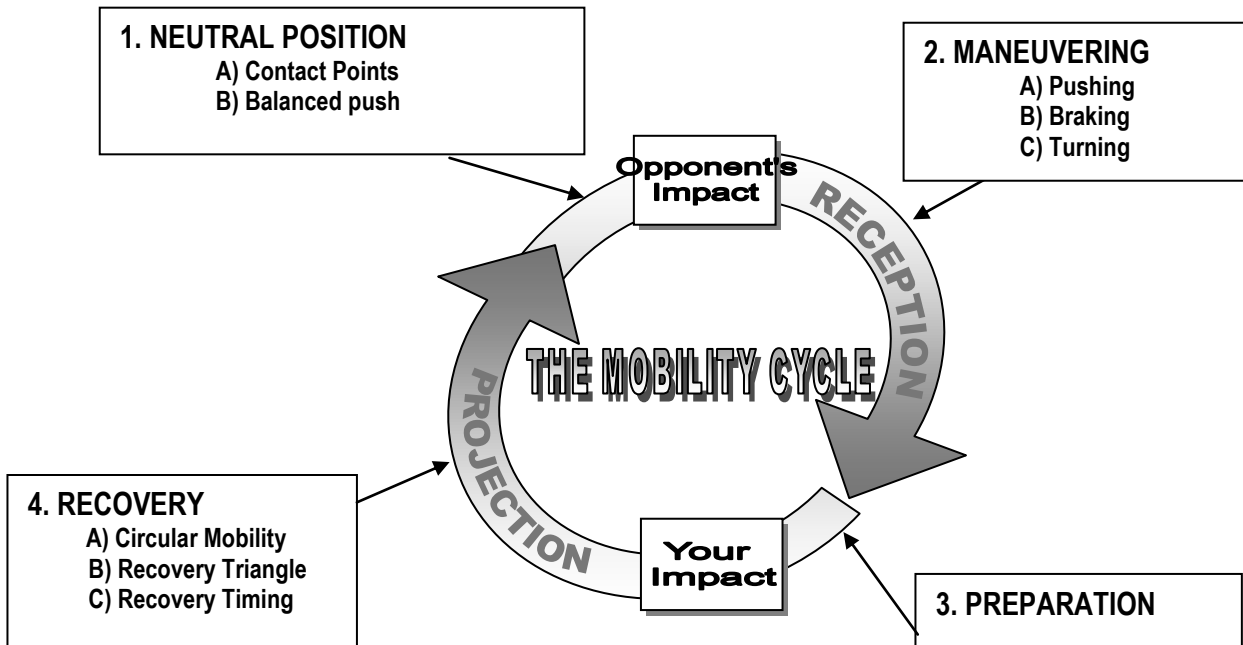
A) Contact Points: These are areas of the hand or racquet grip that connect with some part of the wheel (tire or hand rim). Players commonly use either the pad of the palm against the tire or the forearm. Some use a larger hand rim and others remove the hand rim completely. Whatever the technique, **the main goal is to develop solid contact points.**



FIGURE 15:

B) Ready Position/Balanced Push: It is often an advantage to "overturn" (be angled slightly to the left for a right hander) when in a Neutral Position. This compensates for the stronger push available from the non-racquet hand.

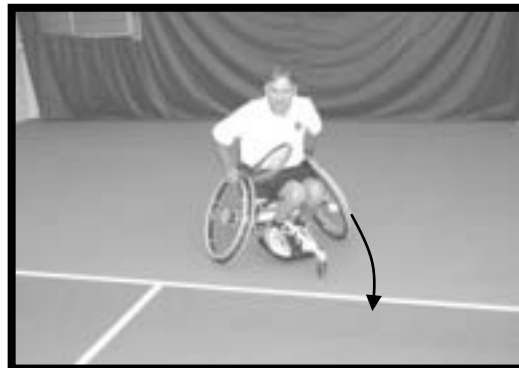

FIGURE 16:

From a Neutral Position a player is better able to 'read' the opponent's shot and react with a strong first push.

2. MANEUVERING

After a player has either anticipated or identified where to go, they must line up the movement of the chair to set up for the best impact point possible.

A) Pushing: In order to propel the chair, the player can thrust with one or both hands. The degree to which each hand is used provides directional control of the chair. Learning to maneuver the chair with a racquet in hand is not easy; it takes time and practice. Any way to push the chair that works is correct. However, in general short quick thrusts are used to start and make fast adjustments. Long thrusts are used once the chair is going and keep the chair accelerating.

B) Braking: This move is done by leaning back in the chair and grabbing both wheels firmly. Once this 'Stutter' is performed, the player can change direction quickly. Just before the opponent's impact, it may be necessary to quickly slow the recovery movement to react more effectively. Braking can also be used when a player feels they are moving to the ball and will get too close (jammed impact).

C) Turning: There are three key ways a player can change direction:

1. **In-Turn:** Turning in towards the net or the centre of the court
2. **Out-Turn:** Turning out away from the net or towards the sidelines
3. **Pivot:** Pulling one wheel and pushing the other to produce an, 'on the spot' turn. This move is often used when a ball is coming right at the player.

FIGURE 17: Turns

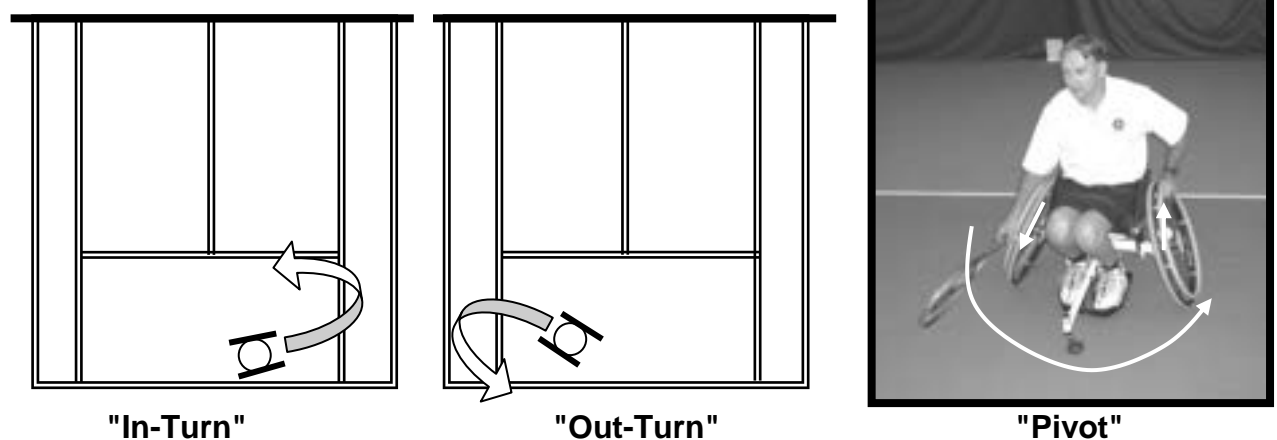

Turns can be executed in 2 ways:

1. **Pull Turn:** Using the movement of the chair to produce a turn by slowing one wheel. This can be done by using the hand on the same side (e.g. left hand on left wheel) or with a "Cross-hand turn" which is done by grasping the wheel with the opposite hand (see photo).
2. **Push Turn:** Pushing more on one wheel to speed it up can also turn the chair.



FIGURE 18: Cross-hand Turn

3. PREPARATION

Once the player is in position (either moving or not) the racquet can then be set for the stroke. In wheelchair tennis the dominant hand must make the transition from pushing to stroking very quickly. Able-bodied players are allowed the luxury of quick leans or back-steps for last minute adjustments in positioning and spacing, while not affecting racquet preparation. Wheelchair players however must use both hands to maneuver the chair for last second adjustments, making racquet preparation difficult. Since the racquet hand is involved in both the Mobility and Racquet Work, ***The timing of the racquet***

hand making the transition from pushing to hitting is crucial. Too early and no positioning adjustments can be made, too late and the stroke becomes a quick uncontrolled 'slap'. As a general guideline, the player should transition their hand from pushing to stroking about the same time as the ball bounces.

FIGURE 19: Preparation



4. RECOVERY

Recovery for a wheelchair player includes many distinct features to maximize positioning.

A) Circular Mobility: As mentioned previously, it's important for players to maintain momentum rather than stopping and starting. To achieve this, they must make constant circles. This is called 'Circular mobility' and is critical in the recovery process to get to the best position to return the next shot on time.

After executing the stroke, players perform a turn to begin recovering for the next shot. These turns can be either an **In-Turn** or an **Out-Turn** depending on the situation.



COACHING NOTE: As a 'rule of thumb', a player should always attempt to perform a "Natural Turn" which is the turn that is most in harmony with the player's chair and swing momentum. This type of turn will allow physics to work best for the player. The exception to the rule is when a player can gain advantage, or minimize an opponent's advantage. In this case a player may choose a, "Counter Turn" which is one that ignores the momentum rule. A Counter Turn is harder to perform but may be worth the effort tactically.

1. Reverse Mobility: When recovering, a player's best ready position is dynamic and is performed while wheeling towards the back fence. This allows the player to keep moving and maintain momentum. The player must look over their shoulder to pick up the information required to decide on an In-Turn or Out-Turn to cut off the opponent's shot.

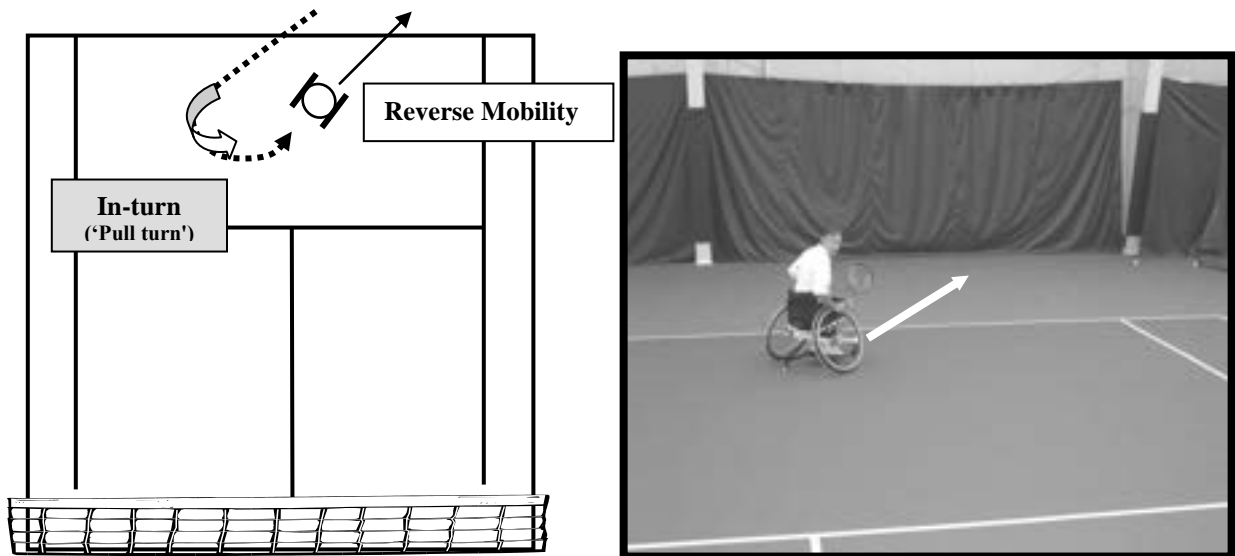

FIGURE 20: Reverse mobility after a forehand

2. "Intersecting" vs "Bisecting": Since wheelchair players are allowed two bounces, it is often more effective to use reverse mobility and turn away from the play and 'intersect' the opponent's shot. This is in contrast to a stand-up player who must 'bisect' the opponent's shot often by going towards it. Moving away from the shot will allow more time, a better court position, and maneuvering room.

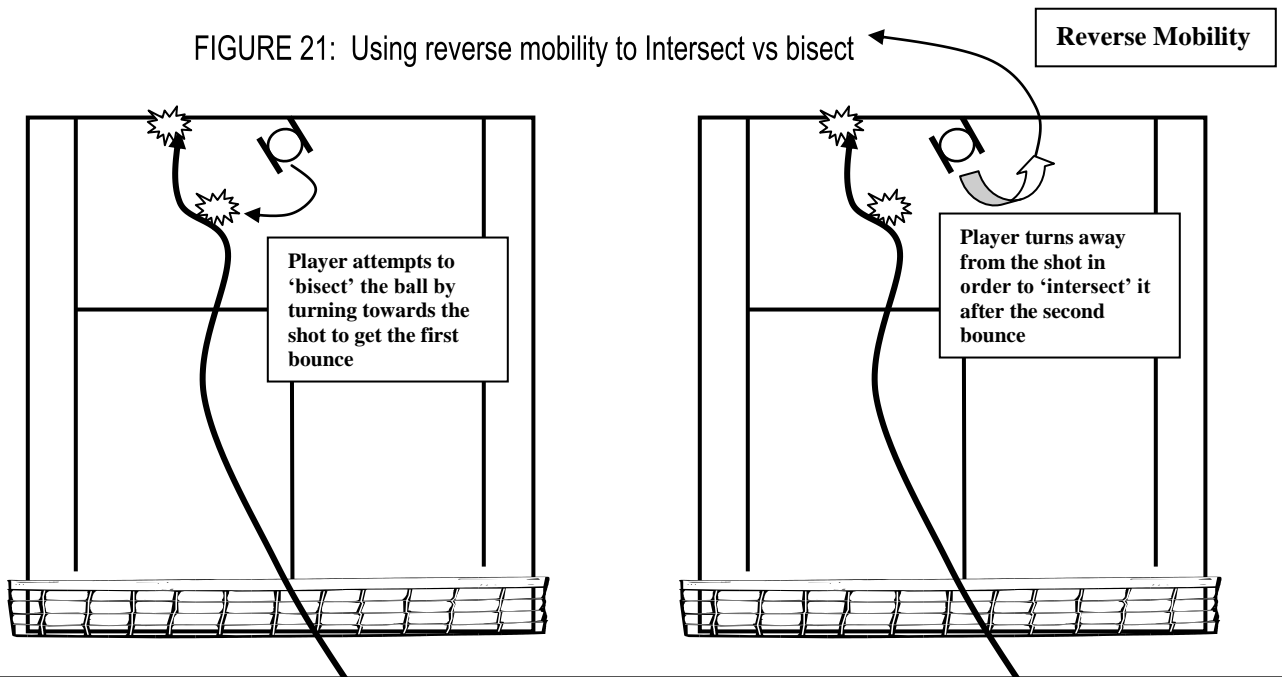

FIGURE 21: Using reverse mobility to Intersect vs bisect

COACHING NOTE: It is natural to want to face the opponent at all times. To "intersect" the ball, it is necessary to turn your back to the opponent. This will seem very strange for most players and it is a good idea to reassure them that this is a good maneuver.

B) Recovery Triangle: It is important for wheelchair players to adopt the best location possible after their shot, to maximize their potential of getting to the next ball.

They must get to a recovery position (often referred to as, the “Hub”) that is equal distance to any shot the opponent hits. This position changes depending on where they have hit the ball.

If we imagine a triangle with the opponent at the peak, the player must recover in between the two ends of the base of the triangle.

FIGURE 22: Recovery locations

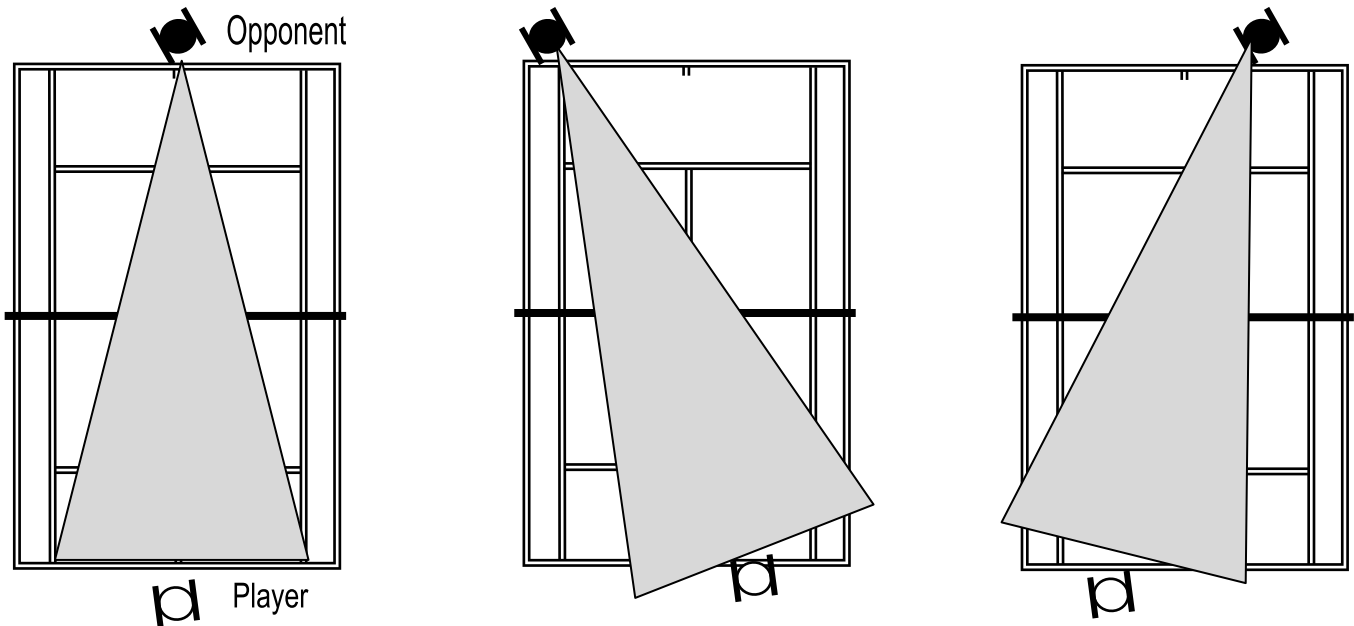

The triangle also lengthens or shortens depending on the strength of the shot the player hits. Sending a strong shot will allow a recovery more inside the baseline to take advantage of the next ball. Conversely, after sending a weak shot, the player may recover more defensively further back.

For the serve, players tend to locate about a chair width behind the baseline to serve (rather than just behind the baseline as all A/B players do). This will allow them to receive a deep return an opponent may hit without turning around and using reverse mobility.

C) Recovery Timing: As important as the location of the recovery is, the timing of arriving at the location is also vital. The player must strive to get to the recovery location just before the opponent hits the ball. They will arrive at this position with their chair still going to the back fence (still in Reverse Mobility). They must however, be looking at the opponent hitting their shot. This will allow the player to react to the shot and take off in the appropriate direction.





A video series on this Mobility Cycle is available on the Tennis Professionals Association (TPA) website: www.tpacanada.ca

MOBILITY CYCLE EXAMPLE

FIGURE 23:

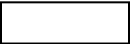
In this example, three Mobility Cycles are linked together starting with the return of serve.

Key:

- Turn description 
- Mobility description 
- Chair 
- Chair movement 
- Impact 
- Turn 

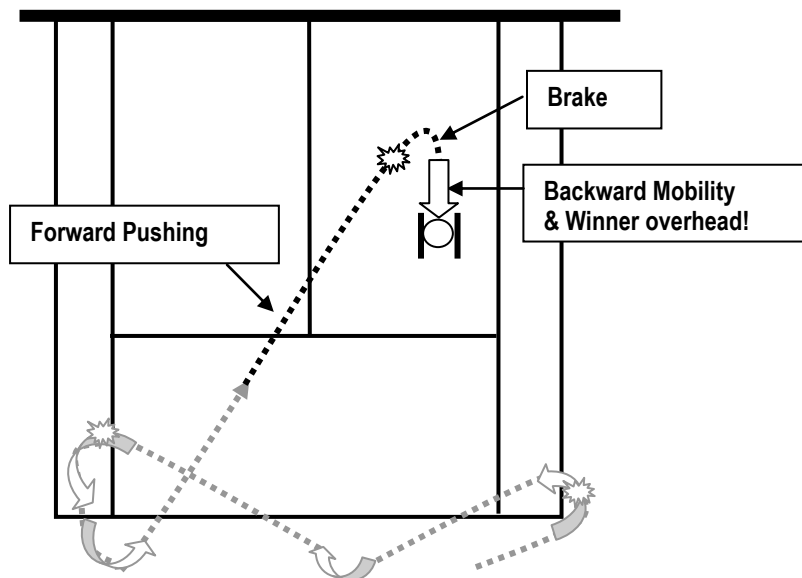
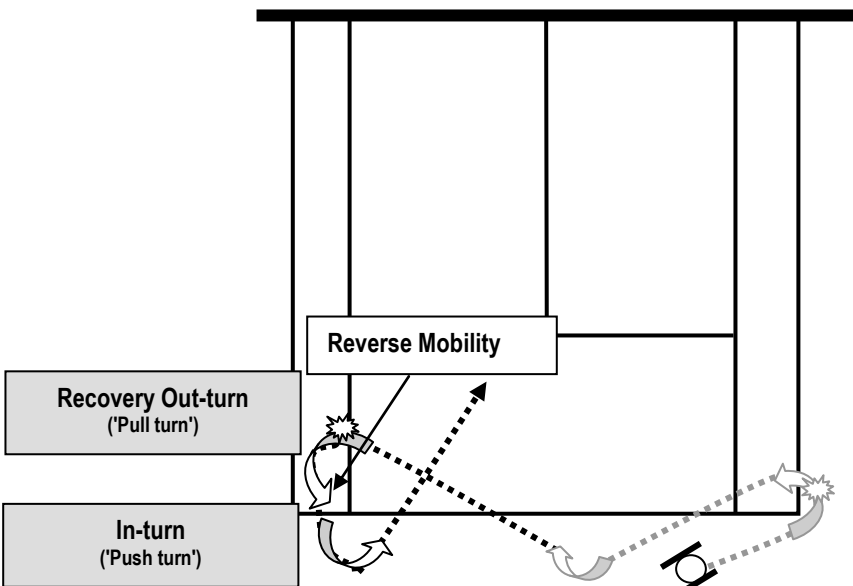
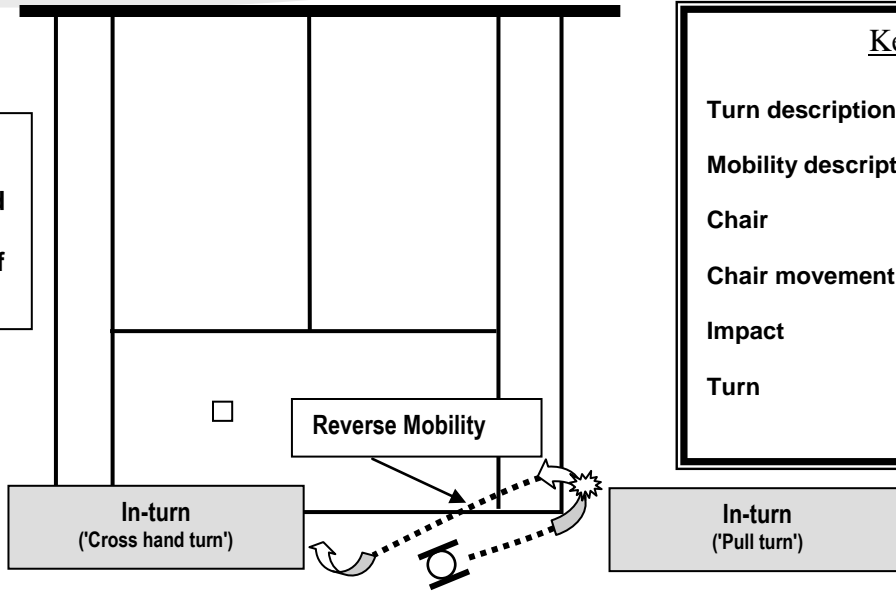

5. MOBILITY DRILLS

A) General mobility drills: The objective of any of these drills is to give players repetition of specific mobility components. Drills can isolate certain components (e.g. 'practice only 'pull turns', etc.) or train combinations of skills. **It is recommended that players hold their racquets when doing mobility drills.**

FIGURE 24: General Mobility Drills

HUB DRILL: Player starts at 'Hub', goes to marker '1', executes a turn (player may simulate stroke), and returns to the 'Hub'. Coach may determine any sequence of markers (Clockwise, counterclockwise, etc.)

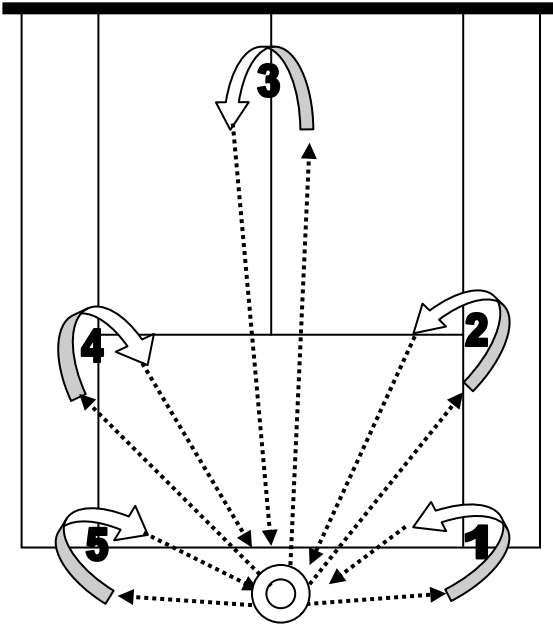

'INDY "500": Player begins at net at 'start' and goes through a circuit of 180 and 45 degree turns. 1-8 players can do this drill at the same time. The 2nd player starts when the 1st has completed the first turn.

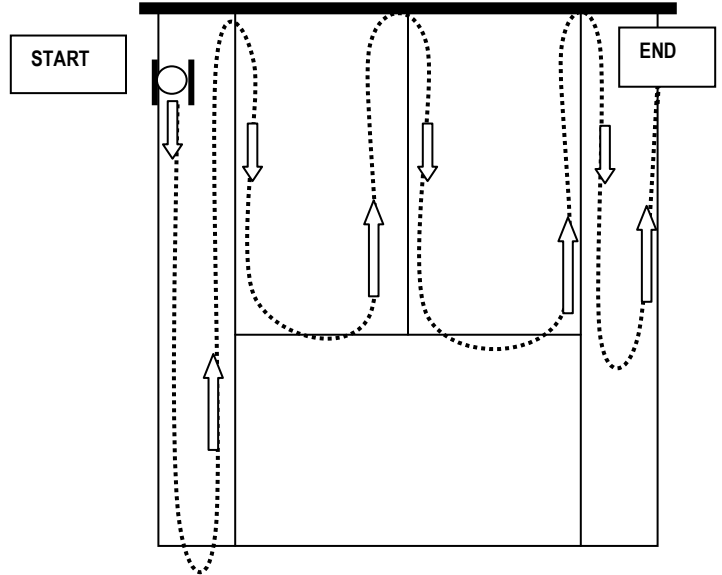

ONE HAND SLALOM: This drill helps to learn and strengthen turning with racquet hand. Player(s) slalom through the circuit using only their racquet hand and combinations of pull & push turns. One full push to start

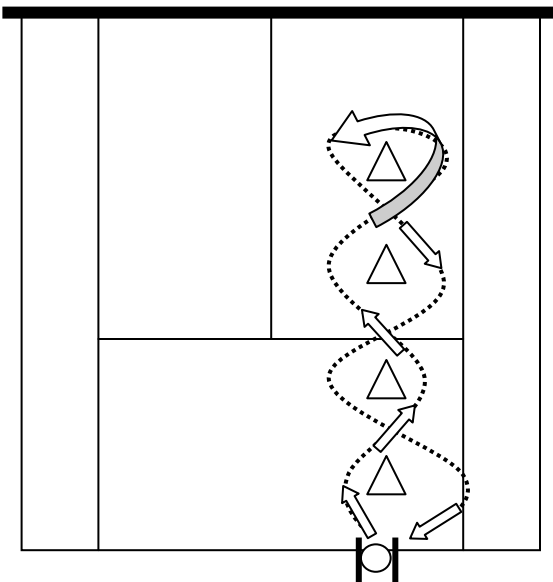

QUICK TURNS: This is for maximum repetition on turns and quick acceleration. The player can also simulate a stroke at each turn. Drill should also be done in the reverse direction.

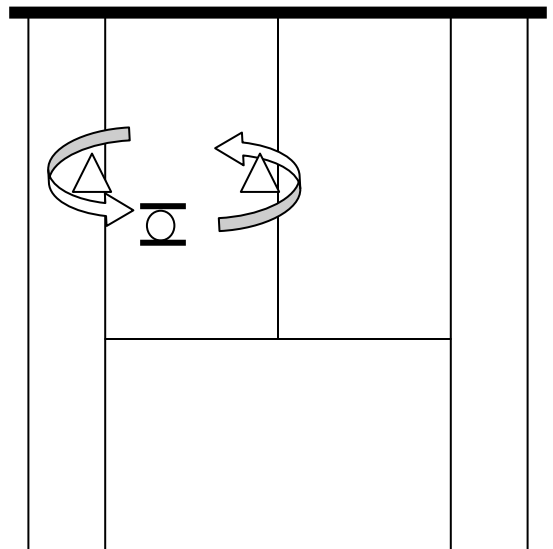

B) Situational Mobility: It is an excellent idea to re-create the specific movements that occur during common situations of play. These drills can be done without hitting the ball or with a basket feed. Many of the drills can be done at any of the development Lengths (e.g. Mini-Tennis, $\frac{3}{4}$ Court, etc.)

FIGURE 25: Situation Drills

HIT & RECOVER: Players rally cooperatively on half a court. After every shot, they must 'go somewhere' to experience moving after a shot. Any movement is fine (e.g. pivot, turn, spin, etc.)

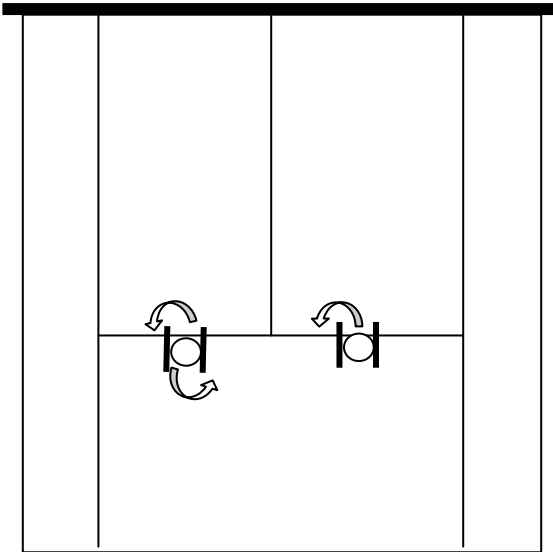

RIGHT AT YOU: Players start facing the net. Balls are fed right at them. Player must pivot and roll backwards out of the way to handle a ball right at them. Player can use forehand or backhand but forehand is recommended.

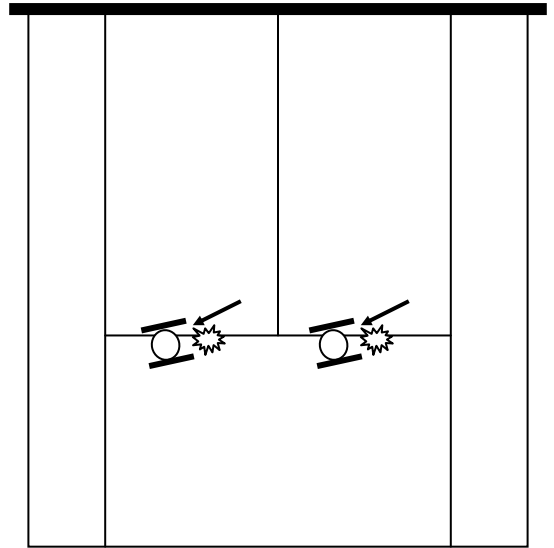

INTERSECT DECISION: Train this 2 shot sequence of a short and deep ball. Player moves in to hit a forehand or backhand. After the shot, recover with reverse mobility and watch the opponent to see which way to turn for the deep ball (2nd shot).

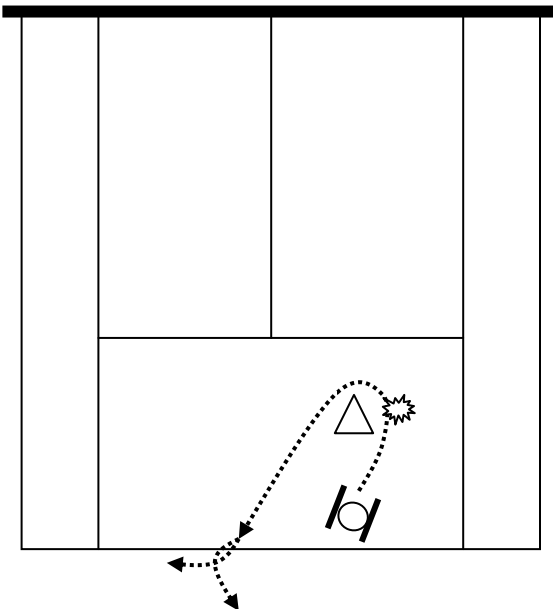
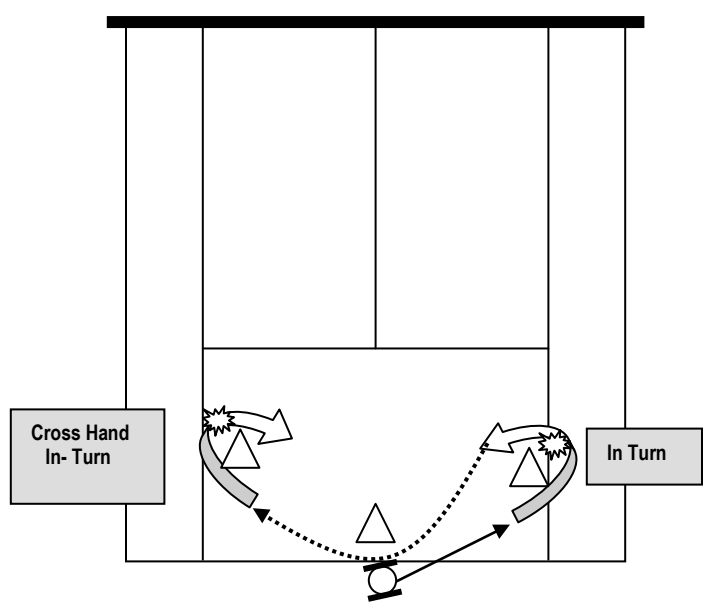
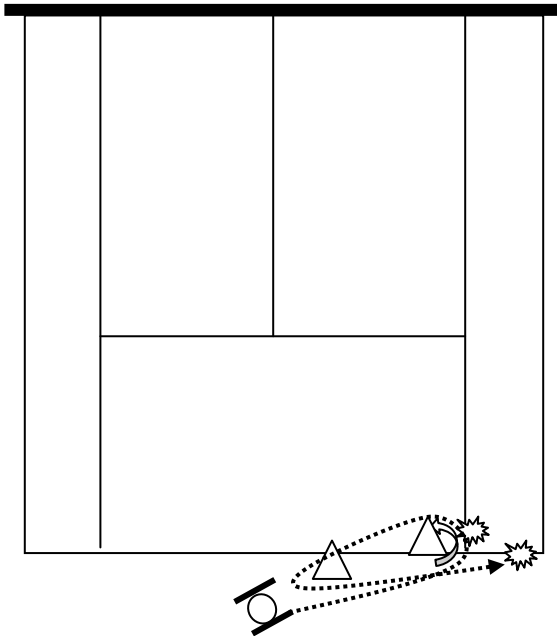

FIGURE 8'S: Player practice In-turns and Cross-hand turns. The player must simulate a stroke at each turn. Drill should also be done in the reverse direction and using Out-turns.



RECEIVING A BALL HIT BEHIND YOU: Player move laterally to hit a forehand or backhand (1st marker). During the recovery, the next ball is sent behind the player who must quickly turn and chase down the ball (around 2nd marker).



IN FOR A VOLLEY: Players start by hitting a forehand or backhand at the baseline (1st marker). They then move in and volley (2nd marker). After the volley they must retrieve a high shot that goes over them (back around 1st marker).

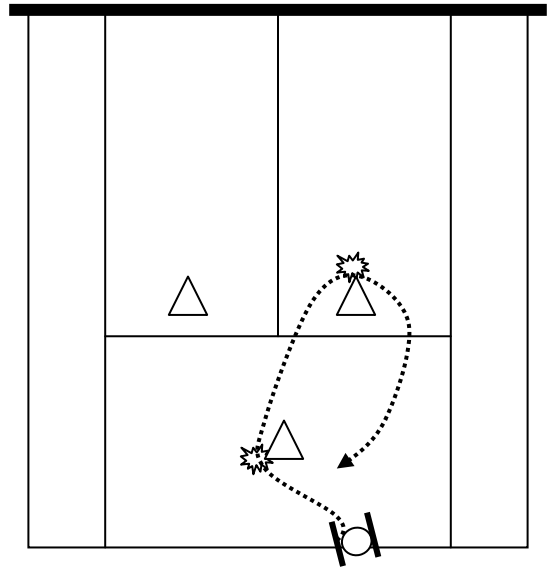

MOVEMENT AFTER A SERVE: Train this 2 shot sequence. Have the player serve (or shadow swing a serve) and move for the next ball. Start with moving for a forehand or backhand wide, then short, then deep. The goal is to complete the sequence of serve & next shot.

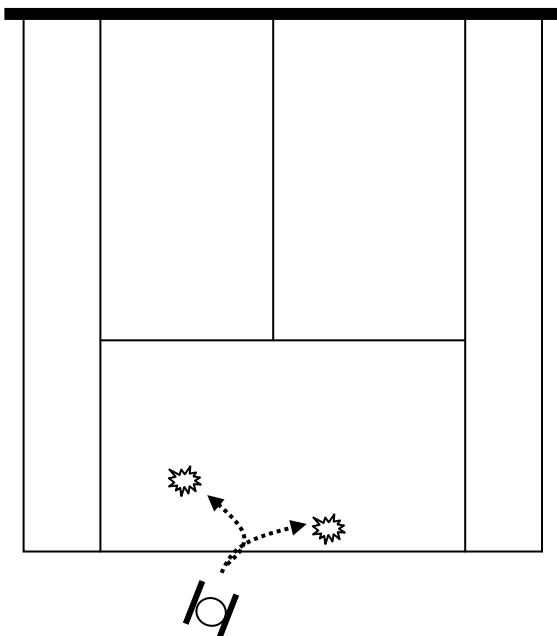

MOVEMENT AFTER A RETURN: Players practice the 2 shot sequence of return and rally. Feeder serves ball to player who returns, recovers and hits the next shot. Sequence should be done from a serve to the forehand and backhand.

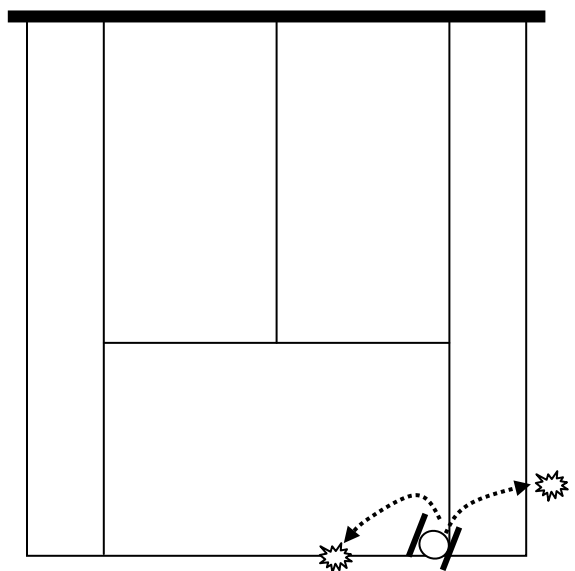



CHECK YOUR UNDERSTANDING

Reflect on these questions regarding the section you have just read.

MOBILITY

Why is it important to keep moving continuously in wheelchair tennis?

What does it mean for a wheelchair player to 'intersect' the ball? Why is that different than a stand-up player?

List the 4 components of the Mobility Cycle? What is the goal of each?

1. _____

2. _____

3. _____

4. _____

What is different about the recovery of a wheelchair player compared the recovery of a stand-up player?

List the three key ways a player can turn and the two ways they can be executed?

1. _____

2. _____

3. _____

Doing an 'In-turn' or an 'Out-turn' depends on which two factors?

1. _____

2. _____

RESOURCES & ACKNOWLEDGEMENTS:

RESOURCES:

The Tennis Professionals' Association (TPA) has a page for wheelchair tennis (www.tpacanada.ca)

Additional information and wheelchair coaching articles are available from the International Tennis Federation website (www.itftennis.com)

Wayne Elderton's website, (www.acecoach.com) has articles of interest to coaches regarding wheelchair tennis.

ACKNOWLEDGEMENTS:

- Special thanks to National Wheelchair Program Consultant, Wayne Elderton for writing and designing this manual and the Wheelchair Instructor Workshop.
- Thanks to Tennis Canada Director of Wheelchair Tennis, Janet Petras for editing and contributing to many parts of the manual.
- Thanks to Canadian National Team Program members Sarah Hunter for contributing the taping tips for Quad players and Phil Rowe for posing for mobility section photographs.
- Thanks to former Tennis Canada Touring Coach, Louis Lamontagne-Müller, and National Coach/Manager, Severine Tamborero for consulting on the 'Mobility' pages.

